

# SC16C750

Universal Asynchronous Receiver/Transmitter (UART)  
with 64-byte FIFO

Rev. 03 — 14 March 2003

Product data

## 1. General description

The SC16C750 is a Universal Asynchronous Receiver and Transmitter (UART) used for serial data communications. Its principal function is to convert parallel data into serial data, and vice versa. The UART can handle serial data rates up to 3 Mbits/s.

The SC16C750 is pin compatible with the TL16C750 and it will power-up to be functionally equivalent to the 16C450. Programming of control registers enables the added features of the SC16C750. Some of these added features are the 64-byte receive and transmit FIFOs, automatic hardware flow control. The selectable auto-flow control feature significantly reduces software overload and increases system efficiency while in FIFO mode by automatically controlling serial data flow using  $\overline{\text{RTS}}$  output and  $\overline{\text{CTS}}$  input signals. The SC16C750 also provides DMA mode data transfers through FIFO trigger levels and the  $\overline{\text{TXRDY}}$  and  $\overline{\text{RXRDY}}$  signals. On-board status registers provide the user with error indications, operational status, and modem interface control. System interrupts may be tailored to meet user requirements. An internal loop-back capability allows on-board diagnostics.

The SC16C750 operates at 5 V, 3.3 V and 2.5 V, the industrial temperature range and is available in plastic PLCC44 and LQFP64 packages.

## 2. Features

- 5 V, 3.3 V and 2.5 V operation
- Industrial temperature range
- After reset, all registers are identical to the typical 16C450 register set
- Capable of running with all existing generic 16C450 software
- Pin compatibility with the industry-standard ST16C450/550, TL16C450/550, PC16C450/550
- Up to 3 Mbits/s transmit/receive operation at 5 V, 2 Mbits/s at 3.3 V, and 1 Mbit/s at 2.5 V
- 64 byte transmit FIFO
- 64 byte receive FIFO with error flags
- Programmable auto- $\overline{\text{RTS}}$  and auto- $\overline{\text{CTS}}$ 
  - ◆ In auto- $\overline{\text{CTS}}$  mode,  $\overline{\text{CTS}}$  controls transmitter
  - ◆ In auto- $\overline{\text{RTS}}$  mode, RxFIFO contents and threshold control  $\overline{\text{RTS}}$
- Automatic hardware flow control
- Software selectable Baud Rate Generator
- Four selectable Receive interrupt trigger levels
- Standard modem interface
- Sleep mode



**PHILIPS**

- Standard asynchronous error and framing bits (Start, Stop, and Parity Overrun Break)
- Independent receiver clock input
- Transmit, Receive, Line Status, and Data Set interrupts independently controlled
- Fully programmable character formatting:
  - ◆ 5-, 6-, 7-, or 8-bit characters
  - ◆ Even-, Odd-, or No-Parity formats
  - ◆ 1-, 1½-, or 2-stop bit
  - ◆ Baud generation (DC to 3 Mbits/s)
- False start-bit detection
- Complete status reporting capabilities
- 3-State output TTL drive capabilities for bi-directional data bus and control bus
- Line Break generation and detection
- Internal diagnostic capabilities:
  - ◆ Loop-back controls for communications link fault isolation
- Prioritized interrupt system controls
- Modem control functions ( $\overline{\text{CTS}}$ ,  $\overline{\text{RTS}}$ ,  $\overline{\text{DSR}}$ ,  $\overline{\text{DTR}}$ ,  $\overline{\text{RI}}$ ,  $\overline{\text{DCD}}$ ).

### 3. Ordering information

**Table 1: Ordering information**

Industrial:  $V_{CC} = 2.5\text{ V}, 3.3\text{ V}$  or  $5\text{ V} \pm 10\%$ ;  $T_{amb} = -40\text{ }^{\circ}\text{C}$  to  $+85\text{ }^{\circ}\text{C}$ .

Type number	Package		
	Name	Description	Version
SC16C750IA44	PLCC44	plastic leaded chip carrier; 44 leads	SOT187-2
SC16C750IB64	LQFP64	plastic low profile quad flat package; 64 leads; $10 \times 10 \times 1.4\text{ mm}$	SOT314-2

4. Block diagram

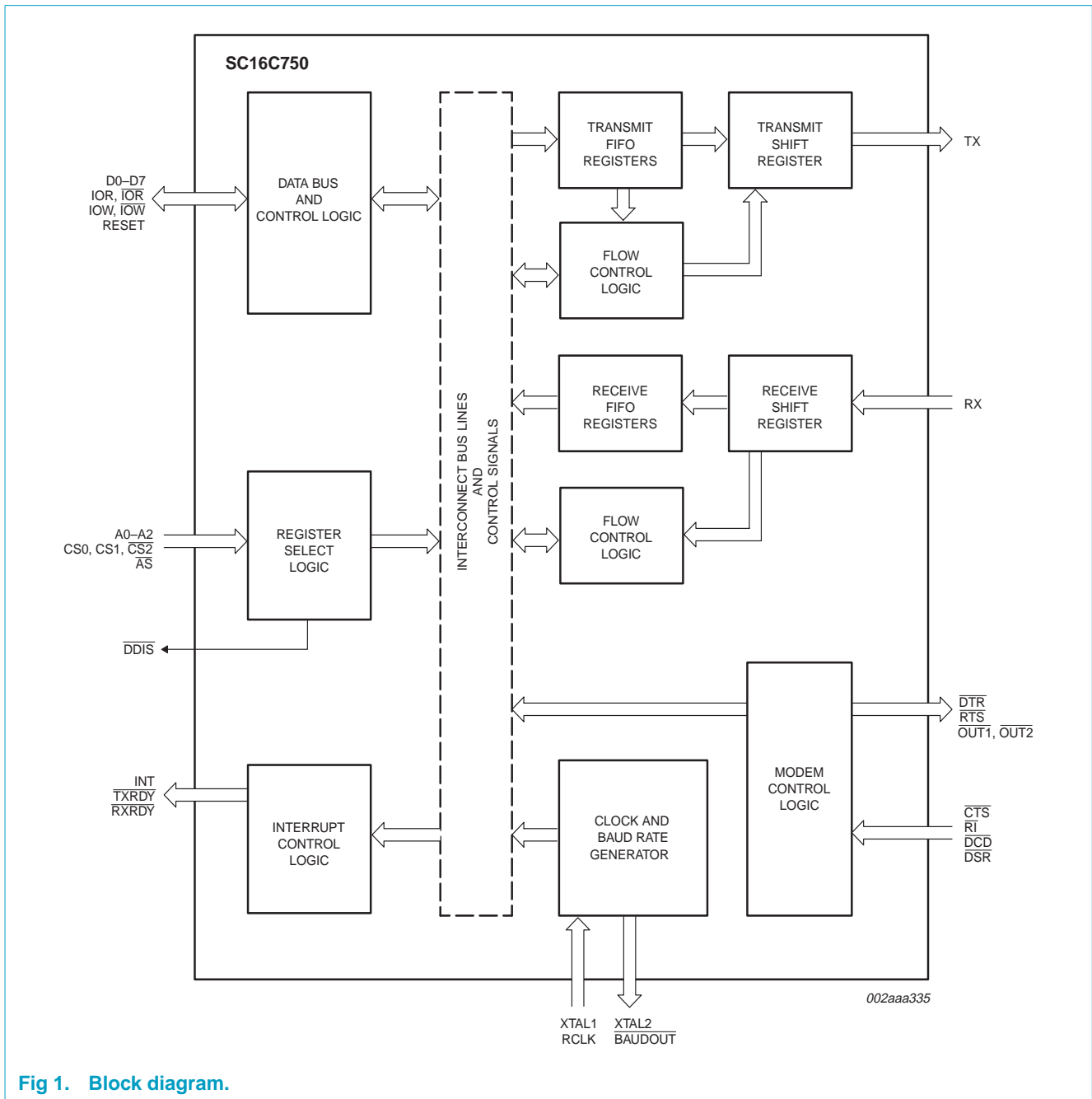
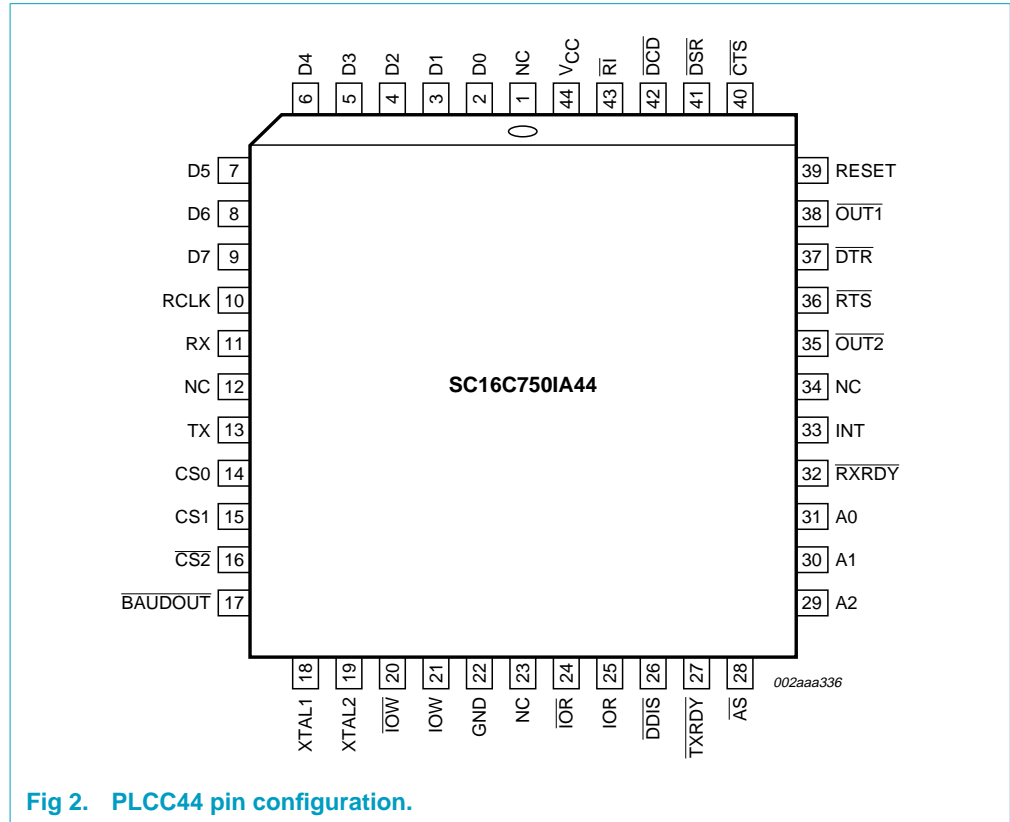

Fig 1. Block diagram.

## 5. Pinning information

### 5.1 Pinning



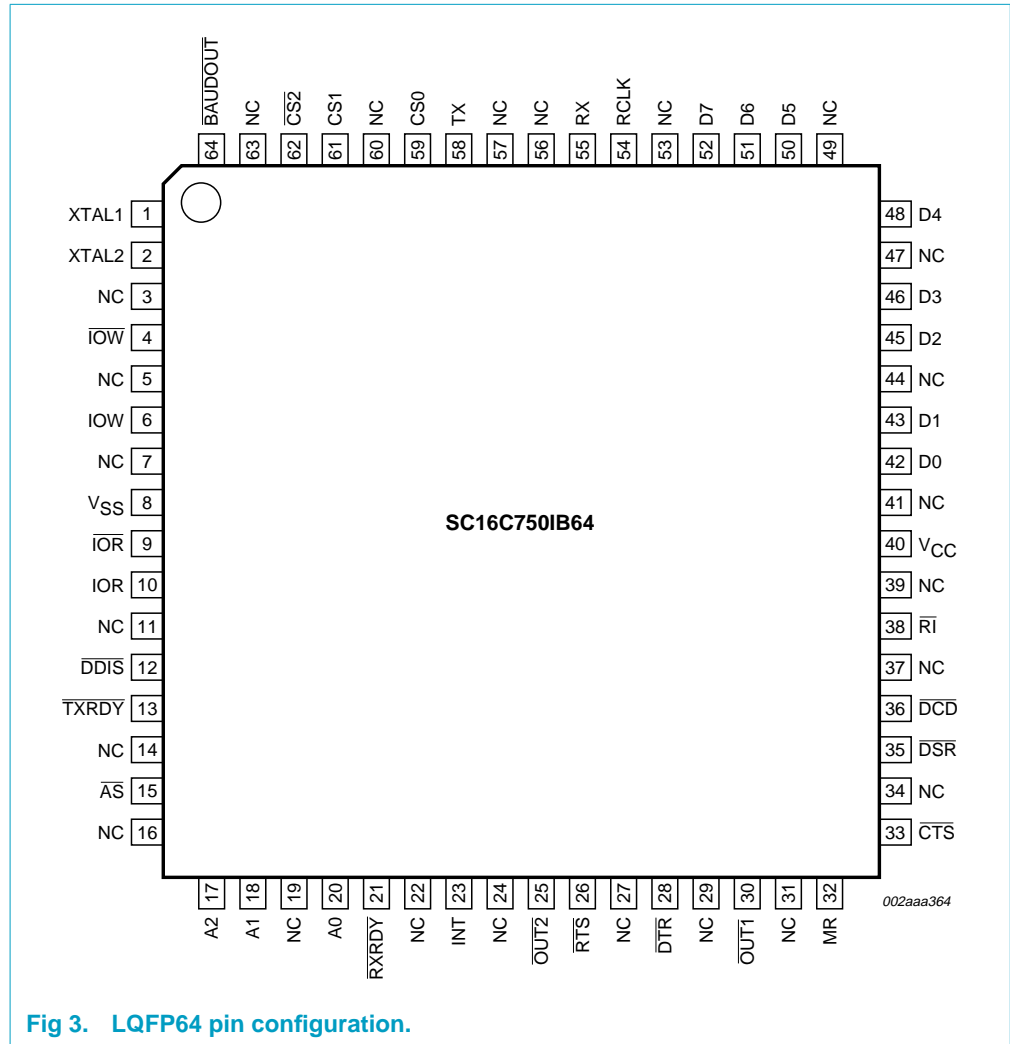

Fig 3. LQFP64 pin configuration.

## 5.2 Pin description

Table 2: Pin description

Symbol	Pin		Type	Description
	PLCC44	LQFP64		
A2-A0	28, 27, 26	17, 18, 20	I	<b>Register select.</b> A0-A2 are used during read and write operations to select the UART register to read from or write to. Refer to Table 3 for register addresses and refer to AS description.
AS	28	15	I	<b>Address strobe.</b> When AS is active (LOW), A0, A1, and A2 and CS0, CS1, and CS2 drive the internal select logic directly; when AS is HIGH, the register select and chip select signals are held at the logic levels they were in when the LOW-to-HIGH transition of AS occurred.
BAUDOUT	17	64	O	<b>Baud out.</b> BAUDOUT is a 16x clock signal for the transmitter section of the UART. The clock rate is established by the reference oscillator frequency divided by a divisor specified in the baud generator divisor latches. BAUDOUT may also be used for the receiver section by tying this output to RCLK.

Table 2: Pin description...continued

Symbol	Pin		Type	Description
	PLCC44	LQFP64		
CS0, CS1, $\overline{\text{CS2}}$	14, 15, 16	59, 61, 62	I	<b>Chip select.</b> When CS0 and CS1 are HIGH and $\overline{\text{CS2}}$ is LOW, these three inputs select the UART. When any of these inputs are inactive, the UART remains inactive (refer to $\overline{\text{AS}}$ description).
$\overline{\text{CTS}}$	40	33	I	<b>Clear to send.</b> $\overline{\text{CTS}}$ is a modem status signal. Its condition can be checked by reading bit 4 (CTS) of the modem status register. Bit 0 ( $\Delta\overline{\text{CTS}}$ ) of the modem status register indicates that $\overline{\text{CTS}}$ has changed states since the last read from the modem status register. If the modem status interrupt is enabled when $\overline{\text{CTS}}$ changes levels and the auto-CTS mode is not enabled, an interrupt is generated. $\overline{\text{CTS}}$ is also used in the auto-CTS mode to control the transmitter.
D7-D0	2-9	52, 51, 50, 48, 46, 45, 43, 42	I/O	<b>Data bus.</b> Eight data lines with 3-State outputs provide a bi-directional path for data, control and status information between the UART and the CPU.
$\overline{\text{DCD}}$	42	36	I	<b>Data carrier detect.</b> $\overline{\text{DCD}}$ is a modem status signal. Its condition can be checked by reading bit 7 (DCD) of the modem status register. Bit 3 ( $\Delta\overline{\text{DCD}}$ ) of the modem status register indicates that $\overline{\text{DCD}}$ has changed states since the last read from the modem status register. If the modem status interrupt is enabled when $\overline{\text{DCD}}$ changes levels, an interrupt is generated.
$\overline{\text{DDIS}}$	26	12	O	<b>Driver disable.</b> $\overline{\text{DDIS}}$ is active (LOW) when the CPU is not reading data. When active, $\overline{\text{DDIS}}$ can disable an external transceiver.
$\overline{\text{DSR}}$	41	35	I	<b>Data set ready.</b> $\overline{\text{DSR}}$ is a modem status signal. Its condition can be checked by reading bit 5 (DSR) of the modem status register. Bit 1 ( $\Delta\overline{\text{DSR}}$ ) of the modem status register indicates $\overline{\text{DSR}}$ has changed levels since the last read from the modem status register. If the modem status interrupt is enabled when $\overline{\text{DSR}}$ changes levels, an interrupt is generated.
$\overline{\text{DTR}}$	37	28	O	<b>Data terminal ready.</b> When active (LOW), $\overline{\text{DTR}}$ informs a modem or data set that the UART is ready to establish communication. $\overline{\text{DTR}}$ is placed in the active level by setting the $\overline{\text{DTR}}$ bit of the modem control register. $\overline{\text{DTR}}$ is placed in the inactive level either as a result of a Master Reset, during loop mode operation, or clearing the DTR bit.
INT	33	23	O	<b>Interrupt.</b> When active (HIGH), INT informs the CPU that the UART has an interrupt to be serviced. Four conditions that cause an interrupt to be issued are: a receiver error, received data that is available or timed out (FIFO mode only), an empty transmitter holding register or an enabled modem status interrupt. INT is reset (deactivated) either when the interrupt is serviced or as a result of a Master Reset.
MR	39	32	I	<b>Master Reset.</b> When active (HIGH), MR clears most UART registers and sets the levels of various output signals.
NC	34	3, 5, 7, 11, 14, 16, 19, 22, 24, 27, 29, 31, 34, 37, 39, 41, 44, 47, 49, 53, 56, 57, 60, 63		Not connected.

Table 2: Pin description...continued

Symbol	Pin		Type	Description
	PLCC44	LQFP64		
$\overline{\text{OUT1}}$ , $\overline{\text{OUT2}}$	38, 35	30, 25	O	<b>Outputs 1 and 2.</b> These are user-designated output terminals that are set to the active (low) level by setting respective modem control register (MCR) bits ( $\overline{\text{OUT1}}$ and $\overline{\text{OUT2}}$ ). $\overline{\text{OUT1}}$ and $\overline{\text{OUT2}}$ are set to inactive the (HIGH) level as a result of Master Reset, during loop mode operations, or by clearing bit 2 ( $\overline{\text{OUT1}}$ ) or bit 3 ( $\overline{\text{OUT2}}$ ) of the MCR.
RCLK	10	54	I	<b>Receiver clock.</b> RCLK is the 16× baud rate clock for the receiver section of the UART.
$\overline{\text{IOR}}$ , IOR	24, 25	9, 10	I	<b>Read inputs.</b> When either $\overline{\text{IOR}}$ or IOR is active (LOW or HIGH, respectively) while the UART is selected, the CPU is allowed to read status information or data from a selected UART register. Only one of these inputs is required for the transfer of data during a read operation; the other input should be tied to its inactive level (i.e., IOR tied LOW or $\overline{\text{IOR}}$ tied HIGH).
$\overline{\text{RI}}$	43	38	I	<b>Ring indicator.</b> $\overline{\text{RI}}$ is a modem status signal. Its condition can be checked by reading bit 6 (RI) of the modem status register. Bit 2 ( $\Delta\overline{\text{RI}}$ ) of the modem status register indicates that $\overline{\text{RI}}$ has transitioned from a LOW to a HIGH level since the last read from the modem status register. If the modem status interrupt is enabled when this transition occurs, an interrupt is generated.
$\overline{\text{RTS}}$	36	26	O	<b>Request to send.</b> When active, $\overline{\text{RTS}}$ informs the modem or data set that the UART is ready to receive data. $\overline{\text{RTS}}$ is set to the active level by setting the $\overline{\text{RTS}}$ modem control register bit and is set to the inactive (HIGH) level either as a result of a Master Reset or during loop mode operations or by clearing bit 1 ( $\overline{\text{RTS}}$ ) of the MCR. In the auto- $\overline{\text{RTS}}$ mode, $\overline{\text{RTS}}$ is set to the inactive level by the receiver threshold control logic.
$\overline{\text{RXRDY}}$	32	21	O	<b>Receiver ready.</b> Receiver direct memory access (DMA) signaling is available with $\overline{\text{RXRDY}}$ . When operating in the FIFO mode, one of two types of DMA signaling can be selected using the FIFO control register bit 3 (FCR[3]). When operating in the 16C450 mode, only DMA mode 0 is allowed. Mode 0 supports single-transfer DMA in which a transfer is made between CPU bus cycles. Mode 1 supports multi-transfer DMA in which multiple transfers are made continuously until the receiver FIFO has been emptied. In DMA mode 0 (FCR0 = 0 or FCR0 = 1, FCR3 = 0), when there is at least one character in the receiver FIFO or receiver holding register, $\overline{\text{RXRDY}}$ is active (LOW). When $\overline{\text{RXRDY}}$ has been active but there are no characters in the FIFO or holding register, $\overline{\text{RXRDY}}$ goes inactive (HIGH). In DMA mode 1 (FCR0 = 1, FCR3 = 1), when the trigger level or the time-out has been reached, $\overline{\text{RXRDY}}$ goes active (LOW); when it has been active but there are no more characters in the FIFO or holding register, it goes inactive (HIGH).
RX	11	55	I	<b>Serial data input.</b> RX is serial data input from a connected communications device.
TX	13	58	I	<b>Serial data output.</b> TX is composite serial data output to a connected communication device. TX is set to the marking (HIGH) level as a result of Master Reset.

Table 2: Pin description...continued

Symbol	Pin		Type	Description
	PLCC44	LQFP64		
$\overline{\text{TXRDY}}$	27	13	O	<b>Transmitter ready.</b> Transmitter DMA signaling is available with $\overline{\text{TXRDY}}$ . When operating in the FIFO mode, one of two types of DMA signaling can be selected using FCR[3]. When operating in the 16C450 mode, only DMA mode 0 is allowed. Mode 0 supports single-transfer DMA in which a transfer is made between CPU bus cycles. Mode 1 supports multi-transfer DMA in which multiple transfers are made continuously until the transmit FIFO has been filled.
$V_{CC}$	44	40	Power	<b>2.5 V, 3 V or 5 V supply voltage.</b>
$V_{SS}$	22	8	Power	<b>Ground voltage.</b>
$\overline{\text{IOW}}$ , IOW	20, 21	4, 6	I	<b>Write inputs.</b> When either $\overline{\text{IOW}}$ or IOW is active (LOW or HIGH, respectively) and while the UART is selected, the CPU is allowed to write control words or data into a selected UART register. Only one of these inputs is required to transfer data during a write operation; the other input should be tied to its inactive level (i.e., IOW tied LOW or $\overline{\text{IOW}}$ tied HIGH).
XTAL1	18	1	I	<b>Crystal connection or External clock input.</b>
XTAL2 <sup>[1]</sup>	19	2	O	<b>Crystal connection or the inversion of XTAL1 if XTAL1 is driven.</b>

[1] In sleep mode, XTAL2 is left floating.



## 6. Functional description

The SC16C750 provides serial asynchronous receive data synchronization, parallel-to-serial and serial-to-parallel data conversions for both the transmitter and receiver sections. These functions are necessary for converting the serial data stream into parallel data that is required with digital data systems. Synchronization for the serial data stream is accomplished by adding start and stop bits to the transmit data to form a data character (character orientated protocol). Data integrity is insured by attaching a parity bit to the data character. The parity bit is checked by the receiver for any transmission bit errors. The SC16C750 is fabricated with an advanced CMOS process to achieve low drain power and high speed requirements.

The SC16C750 is an upward solution that provides 64 bytes of transmit and receive FIFO memory, instead of none in the 16C450, or 16 in the 16C550. The SC16C750 is designed to work with high speed modems and shared network environments that require fast data processing time. Increased performance is realized in the SC16C750 by the larger transmit and receive FIFOs. This allows the external processor to handle more networking tasks within a given time. In addition, the four selectable levels of FIFO trigger interrupt and automatic hardware flow control is uniquely provided for maximum data throughput performance, especially when operating in a multi-channel environment. The combination of the above greatly reduces the bandwidth requirement of the external controlling CPU, increases performance, and reduces power consumption.

The SC16C750 is capable of operation up to 3 Mbits/s with a 48 MHz external clock input (at 5 V).

The rich feature set of the SC16C750 is available through internal registers. Automatic hardware flow control, selectable transmit and receive FIFO trigger level, selectable TX and RX baud rates, modem interface controls, and a sleep mode are some of these features.

### 6.1 Internal registers

The SC16C750 provides 15 internal registers for monitoring and control. These registers are shown in [Table 3](#). Twelve registers are similar to those already available in the standard 16C550. These registers function as data holding registers (THR/RHR), interrupt status and control registers (IER/ISR), a FIFO control register (FCR), line status and control registers (LCR/LSR), modem status and control registers (MCR/MSR), programmable data rate (clock) control registers (DLL/DLM), and a user accessible scratchpad register (SPR). Beyond the general 16C550 features and capabilities, the SC16C750 offers an enhanced feature register that provides on-board hardware flow control. Register functions are more fully described in the following paragraphs.

Table 3: Internal registers decoding

A2	A1	A0	READ mode	WRITE mode
<b>General register set (THR/RHR, IER/ISR, MCR/MSR, FCR, LSR, SPR)<sup>[1]</sup></b>				
0	0	0	Receive Holding Register	Transmit Holding Register
0	0	1		Interrupt Enable Register
0	1	0	Interrupt Status Register	FIFO Control Register
0	1	1		Line Control Register
1	0	0		Modem Control Register
1	0	1	Line Status Register	n/a
1	1	0	Modem Status Register	n/a
1	1	1	Scratchpad Register	Scratchpad Register
<b>Baud rate register set (DLL/DLM)<sup>[2]</sup></b>				
0	0	0	LSB of Divisor Latch	LSB of Divisor Latch
0	0	1	MSB of Divisor Latch	MSB of Divisor Latch
<b>Enhanced register set (EFR, Xon/off 1-2)<sup>[3]</sup></b>				
0	1	0	Enhanced Feature Register	Enhanced Feature Register
1	0	0	Xon1 word	Xon1 word
1	0	1	Xon2 word	Xon2 word
1	1	0	Xoff1 word	Xoff1 word
1	1	1	Xoff2 word	Xoff2 word

[1] These registers are accessible only when LCR[7] is a logic 0.

[2] These registers are accessible only when LCR[7] is a logic 1.

[3] Enhanced Feature Register, Xon1, 2 and Xoff1, 2 are accessible only when the LCR is set to 'BF(HEX)'.

## 6.2 FIFO operation

The 64-byte transmit and receive data FIFOs are enabled by the FIFO Control Register bit-0 (FCR[0]). With 16C550 devices, the user can set the receive trigger level, but not the transmit trigger level. The SC16C750 provides independent trigger levels for both receiver and transmitter. To remain compatible with SC16C550, the transmit interrupt trigger level is set to 16 following a reset. It should be noted that the user can set the transmit trigger levels by writing to the FCR register, but activation will not take place until EFR[4] is set to a logic 1. The receiver FIFO section includes a time-out function to ensure data is delivered to the external CPU. An interrupt is generated whenever the Receive Holding Register (RHR) has not been read following the loading of a character or the receive trigger level has not been reached.

Table 4: Flow control mechanism

Selected trigger level (characters)	INT pin activation	Negate RTS	Assert RTS
<b>16-byte FIFO</b>			
1	1	4	1
4	4	8	4
8	8	12	8
14	14	14	10

Table 4: Flow control mechanism...continued

Selected trigger level (characters)	INT pin activation	Negate $\overline{\text{RTS}}$	Assert $\overline{\text{RTS}}$
<b>64-byte FIFO</b>			
1	1	16	1
16	16	32	8
32	32	56	16
56	56	60	32

### 6.3 Hardware flow control

When automatic hardware flow control is enabled, the SC16C750 monitors the  $\overline{\text{CTS}}$  pin for a remote buffer overflow indication and controls the  $\overline{\text{RTS}}$  pin for local buffer overflows. Automatic hardware flow control is selected by setting EFR[6] (RTS) and EFR[7] (CTS) to a logic 1. If  $\overline{\text{CTS}}$  transitions from a logic 0 to a logic 1 indicating a flow control request, the SC16C750 will suspend TX transmissions as soon as the stop bit of the character in process is shifted out. Transmission is resumed after the  $\overline{\text{CTS}}$  input returns to a logic 0, indicating more data may be sent.

With the Auto-RTS function enabled, an interrupt is generated when the receive FIFO reaches the programmed trigger level. The  $\overline{\text{RTS}}$  pin will not be forced to a logic 1 (RTS off), until the receive FIFO reaches the next trigger level. However, the  $\overline{\text{RTS}}$  pin will return to a logic 0 after the data buffer (FIFO) is unloaded to the next trigger level below the programmed trigger level. However, under the above described conditions, the SC16C750 will continue to accept data until the receive FIFO is full.

### 6.4 Time-out interrupts

When two interrupt conditions have the same priority, it is important to service these interrupts correctly. Receive Data Ready and Receive Time Out have the same interrupt priority (when enabled by IER[0]). The receiver issues an interrupt after the number of characters have reached the programmed trigger level. In this case, the SC16C750 FIFO may hold more characters than the programmed trigger level. Following the removal of a data byte, the user should re-check LSR[0] for additional characters. A Receive Time Out will not occur if the receive FIFO is empty. The time-out counter is reset at the center of each stop bit received or each time the receive holding register (RHR) is read. The actual time-out value is 4 character time.

## 6.5 Programmable baud rate generator

The SC16C750 supports high speed modem technologies that have increased input data rates by employing data compression schemes. For example, a 33.6 kbit/s modem that employs data compression may require a 115.2 kbit/s input data rate. A 128.0 kbit/s ISDN modem that supports data compression may need an input data rate of 460.8 kbit/s.

A single baud rate generator is provided for the transmitter and receiver, allowing independent TX/RX channel control. The programmable Baud Rate Generator is capable of accepting an input clock up to 48 MHz, as required for supporting a 3 Mbits/s data rate. The SC16C750 can be configured for internal or external clock operation. For internal clock oscillator operation, an industry standard microprocessor crystal (parallel resonant/22-33 pF load) is connected externally between the XTAL1 and XTAL2 pins (see Figure 4). Alternatively, an external clock can be connected to the XTAL1 pin to clock the internal baud rate generator for standard or custom rates (see Table 5).

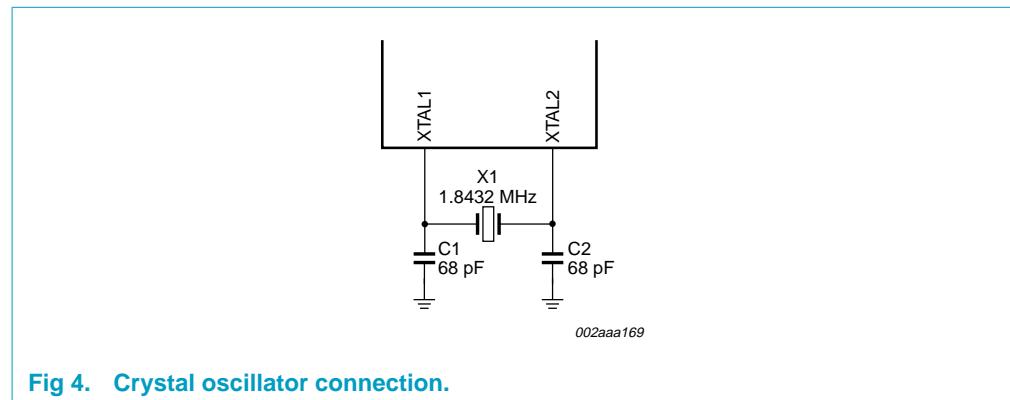

Fig 4. Crystal oscillator connection.

The generator divides the input  $16\times$  clock by any divisor from 1 to  $2^{16} - 1$ . The SC16C750 divides the basic crystal or external clock by 16. The frequency of the  $\overline{\text{BAUDOUT}}$  output pin is exactly  $16\times$  (16 times) of the selected baud rate ( $\overline{\text{BAUDOUT}} = 16 \text{ Baud Rate}$ ). Customized baud rates can be achieved by selecting the proper divisor values for the MSB and LSB sections of baud rate generator.

Programming the Baud Rate Generator registers DLM (MSB) and DLL (LSB) provides a user capability for selecting the desired final baud rate. The example in Table 5 shows selectable baud rates when using a 1.8432 MHz crystal.

For custom baud rates, the divisor value can be calculated using the following equation:

$$\text{Divisor (in decimal)} = \frac{\text{XTAL1 clock frequency}}{\text{serial data rate} \times 16} \quad (1)$$

Table 5: Baud rates using 1.8432 MHz or 3.072 MHz crystal

Using 1.8432 MHz crystal			Using 3.072 MHz crystal		
Desired baud rate	Divisor for 16× clock	Baud rate error	Desired baud rate	Divisor for 16× clock	Baud rate error
50	2304		50	3840	
75	1536		75	2560	
110	1047	0.026	110	1745	0.026
134.5	857	0.058	134.5	1428	0.034
150	768		150	1280	
300	384		300	640	
600	192		600	320	
1200	96		1200	160	
1800	64		1800	107	0.312
2000	58	0.69	2000	96	
2400	48		2400	80	
3600	32		3600	53	0.628
4800	24		4800	40	
7200	16		7200	27	1.23
9600	12		9600	20	
19200	6		19200	10	
38400	3		38400	5	
56000	2	2.86			

## 6.6 DMA operation

The SC16C750 FIFO trigger level provides additional flexibility to the user for block mode operation. The user can optionally operate the transmit and receive FIFOs in the DMA mode (FCR[3]). The DMA mode affects the state of the  $\overline{\text{RXRDY}}$  and  $\overline{\text{TXRDY}}$  output pins. Tables 6 and 7 show this.

Table 6: Effect of DMA mode on state of  $\overline{\text{RXRDY}}$  pin

Non-DMA mode	DMA mode
1 = FIFO empty	0-to-1 transition when FIFO empties
0 = at least 1 byte in FIFO	1-to-0 transition when FIFO reaches trigger level, or time-out occurs

Table 7: Effect of DMA mode on state of  $\overline{\text{TXRDY}}$  pin

Non-DMA mode	DMA mode
1 = at least 1 byte in FIFO	0-to-1 transition when FIFO becomes full
0 = FIFO empty	1-to-0 transition when FIFO goes below trigger level

## 6.7 Sleep mode

The SC16C750 is designed to operate with low power consumption. A special sleep mode is included to further reduce power consumption when the chip is not being used. With IER[4] enabled (set to a logic 1), the SC16C750 enters the sleep mode, but resumes normal operation when a start bit is detected, a change of state on any of the modem input pins RX,  $\overline{RI}$ , CTS,  $\overline{DSR}$ ,  $\overline{DCD}$ , or a transmit data is provided by the user. If the sleep mode is enabled and the SC16C750 is awakened by one of the conditions described above, it will return to the sleep mode automatically after the last character is transmitted or read by the user. In any case, the sleep mode will not be entered while an interrupt(s) is pending. The SC16C750 will stay in the sleep mode of operation until it is disabled by setting IER[4] to a logic 0.

## 6.8 Loop-back mode

The internal loop-back capability allows on-board diagnostics. In the loop-back mode, the normal modem interface pins are disconnected and reconfigured for loop-back internally. MCR[0-3] register bits are used for controlling loop-back diagnostic testing. In the loop-back mode, OUT1 and OUT2 in the MCR register (bits 2-3) control the modem  $\overline{RI}$  and  $\overline{DCD}$  inputs, respectively. MCR signals  $\overline{DTR}$  and  $\overline{RTS}$  (bits 0-1) are used to control the modem CTS and  $\overline{DSR}$  inputs, respectively. The transmitter output (TX) and the receiver input (RX) are disconnected from their associated interface pins, and instead are connected together internally (see Figure 5). The  $\overline{CTS}$ ,  $\overline{DSR}$ ,  $\overline{DCD}$ , and  $\overline{RI}$  are disconnected from their normal modem control input pins, and instead are connected internally to  $\overline{DTR}$ ,  $\overline{RTS}$ , OUT1 and OUT2. Loop-back test data is entered into the transmit holding register via the user data bus interface, D0-D7. The transmit UART serializes the data and passes the serial data to the receive UART via the internal loop-back connection. The receive UART converts the serial data back into parallel data that is then made available at the user data interface D0-D7. The user optionally compares the received data to the initial transmitted data for verifying error-free operation of the UART TX/RX circuits.

In this mode, the receiver and transmitter interrupts are fully operational. The Modem Control Interrupts are also operational. However, the interrupts can only be read using lower four bits of the Modem Status Register (MSR[0-3]) instead of the four Modem Status Register bits 4-7. The interrupts are still controlled by the IER.

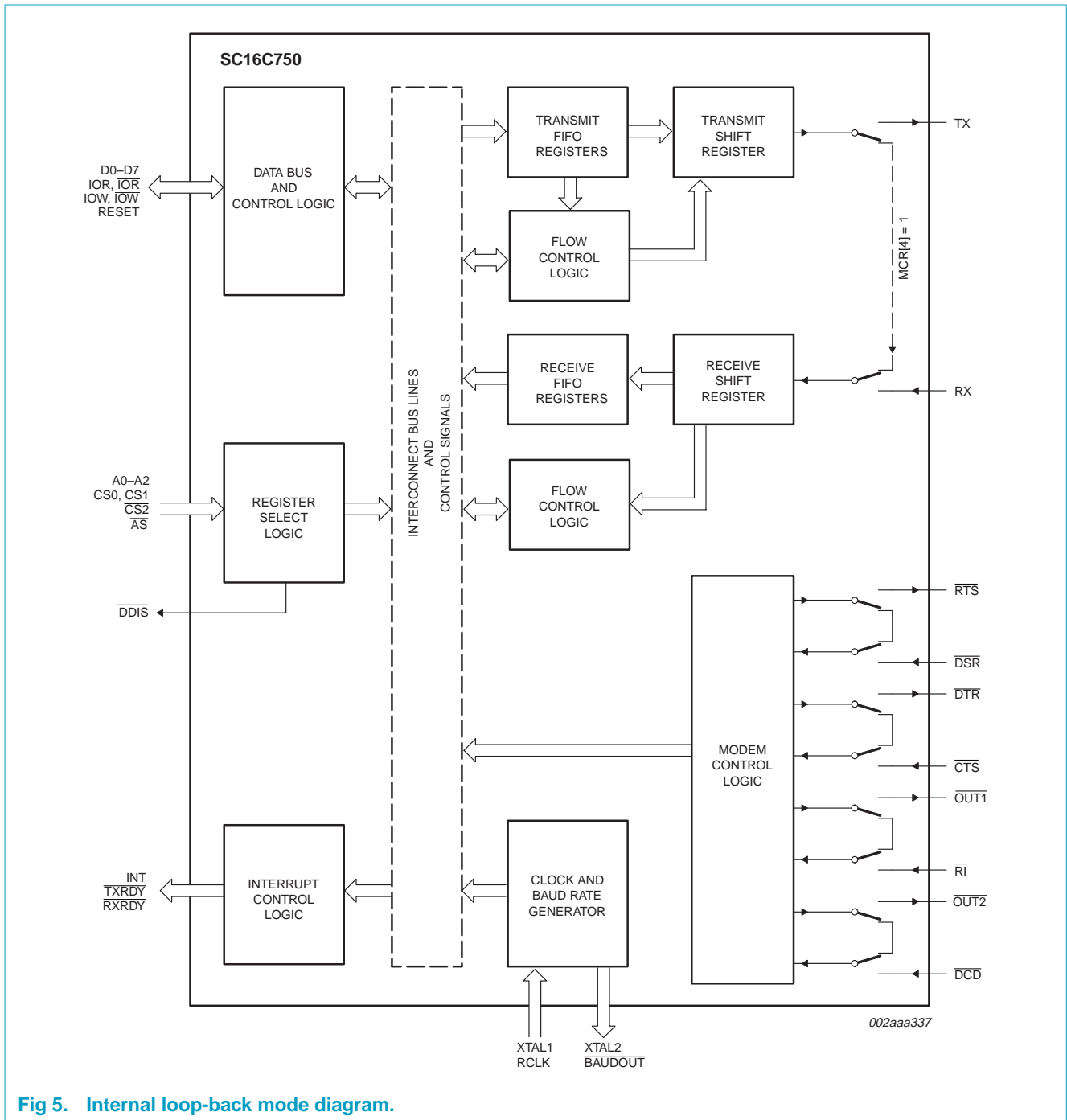

Fig 5. Internal loop-back mode diagram.

## 7. Register descriptions

Table 8 details the assigned bit functions for the fifteen SC16C750 internal registers. The assigned bit functions are more fully defined in Section 7.1 through Section 7.11.

Table 8: SC16C750 internal registers

A2	A1	A0	Register	Default <sup>[1]</sup>	Bit 7	Bit 6	Bit 5	Bit 4	Bit 3	Bit 2	Bit 1	Bit 0
<b>General Register Set<sup>[2]</sup></b>												
0	0	0	RHR	XX	bit 7	bit 6	bit 5	bit 4	bit 3	bit 2	bit 1	bit 0
0	0	0	THR	XX	bit 7	bit 6	bit 5	bit 4	bit 3	bit 2	bit 1	bit 0
0	0	1	IER	00	0	0	low power mode	Sleep mode	modem status interrupt	receive line status interrupt	transmit holding register	receive holding register
0	1	0	FCR	00	RCVR trigger (MSB)	RCVR trigger (LSB)	64-byte FIFO enable	reserved	DMA mode select	XMIT FIFO reset	RCVR FIFO reset	FIFO enable
0	1	0	ISR	01	FIFOs enabled	FIFOs enabled	64-byte FIFO enable	0	INT priority bit 2	INT priority bit 1	INT priority bit 0	INT status
0	1	1	LCR	00	divisor latch enable	set break	set parity	even parity	parity enable	stop bits	word length bit 1	word length bit 0
1	0	0	MCR	00	0	0	reserved	loop back	OUT2, INT enable	OUT1	RTS	DTR
1	0	1	LSR	60	FIFO data error	trans. empty	trans. holding empty	break interrupt	framing error	parity error	overrun error	receive data ready
1	1	0	MSR	X0	DCD	RI	DSR	CTS	$\Delta$ DCD	$\Delta$ RI	$\Delta$ DSR	$\Delta$ CTS
1	1	1	SPR	FF	bit 7	bit 6	bit 5	bit 4	bit 3	bit 2	bit 1	bit 0
<b>Special Register Set<sup>[3]</sup></b>												
0	0	0	DLL	XX	bit 7	bit 6	bit 5	bit 4	bit 3	bit 2	bit 1	bit 0
0	0	1	DLM	XX	bit 15	bit 14	bit 13	bit 12	bit 11	bit 10	bit 9	bit 8
<b>Enhanced Register Set<sup>[4]</sup></b>												
0	1	0	EFR	00	Auto CTS	Auto RTS	0	0	0	0	0	0

[1] The value shown represents the register's initialized HEX value; X = n/a.

[2] These registers are accessible only when LCR[7] = 0.

[3] The Special Register set is accessible only when LCR[7] is set to a logic 1.

[4] Enhanced Feature Register is accessible only when LCR is set to 'BF<sub>Hex</sub>'.



## 7.1 Transmit (THR) and Receive (RHR) Holding Registers

The serial transmitter section consists of an 8-bit Transmit Hold Register (THR) and Transmit Shift Register (TSR). The status of the THR is provided in the Line Status Register (LSR). Writing to the THR transfers the contents of the data bus (D7-D0) to the THR, providing that the THR or TSR is empty. The THR empty flag in the LSR register will be set to a logic 1 when the transmitter is empty or when data is transferred to the TSR. Note that a write operation can be performed when the THR empty flag is set (logic 0 = FIFO full; logic 1 = at least one FIFO location available).

The serial receive section also contains an 8-bit Receive Holding Register (RHR). Receive data is removed from the SC16C750 and receive FIFO by reading the RHR register. The receive section provides a mechanism to prevent false starts. On the falling edge of a start or false start bit, an internal receiver counter starts counting clocks at the  $16\times$  clock rate. After  $7\frac{1}{2}$  clocks, the start bit time should be shifted to the center of the start bit. At this time the start bit is sampled, and if it is still a logic 0 it is validated. Evaluating the start bit in this manner prevents the receiver from assembling a false character. Receiver status codes will be posted in the LSR.

## 7.2 Interrupt Enable Register (IER)

The Interrupt Enable Register (IER) masks the interrupts from receiver ready, transmitter empty, line status and modem status registers. These interrupts would normally be seen on the INT output pin.

**Table 9: Interrupt Enable Register bits description**

Bit	Symbol	Description
7-6	IER[7], IER[6]	Not used.
5	IER[5]	Low power mode. Logic 0 = Disable low power mode (normal default condition). Logic 1 = Enable low power mode.
4	IER[4]	Sleep mode. Logic 0 = Disable sleep mode (normal default condition). Logic 1 = Enable sleep mode. See <a href="#">Section 6.7 "Sleep mode"</a> for details.
3	IER[3]	Modem Status Interrupt. Logic 0 = Disable the modem status register interrupt (normal default condition). Logic 1 = Enable the modem status register interrupt.
2	IER[2]	Receive Line Status interrupt. This interrupt will be issued whenever a fully assembled receive character is transferred from RSR to the RHR/FIFO, i.e., data ready, LSR[0]. Logic 0 = Disable the receiver line status interrupt (normal default condition). Logic 1 = Enable the receiver line status interrupt.

**Table 9:** Interrupt Enable Register bits description...continued

Bit	Symbol	Description
1	IER[1]	Transmit Holding Register interrupt. This interrupt will be issued whenever the THR is empty, and is associated with LSR[1]. Logic 0 = Disable the transmitter empty interrupt (normal default condition). Logic 1 = Enable the transmitter empty interrupt.
0	IER[0]	Receive Holding Register interrupt. This interrupt will be issued when the FIFO has reached the programmed trigger level, or is cleared when the FIFO drops below the trigger level in the FIFO mode of operation. Logic 0 = Disable the receiver ready interrupt (normal default condition). Logic 1 = Enable the receiver ready interrupt.

### 7.2.1 IER versus Receive FIFO interrupt mode operation

When the receive FIFO (FCR[0] = logic 1), and receive interrupts (IER[0] = logic 1) are enabled, the receive interrupts and register status will reflect the following:

- The receive data available interrupts are issued to the external CPU when the FIFO has reached the programmed trigger level. It will be cleared when the FIFO drops below the programmed trigger level.
- FIFO status will also be reflected in the user accessible ISR register when the FIFO trigger level is reached. Both the ISR register status bit and the interrupt will be cleared when the FIFO drops below the trigger level.
- The data ready bit (LSR[0]) is set as soon as a character is transferred from the shift register to the receive FIFO. It is reset when the FIFO is empty.

### 7.2.2 IER versus Receive/Transmit FIFO polled mode operation

When FCR[0] = logic 1, resetting IER[0-3] enables the SC16C750 in the FIFO polled mode of operation. Since the receiver and transmitter have separate bits in the LSR, either or both can be used in the polled mode by selecting respective transmit or receive control bit(s).

- LSR[0] will be a logic 1 as long as there is one byte in the receive FIFO.
- LSR[1-4] will provide the type of errors encountered, if any.
- LSR[5] will indicate when the transmit FIFO is empty.
- LSR[6] will indicate when both the transmit FIFO and transmit shift register are empty.
- LSR[7] will indicate any FIFO data errors.

### 7.3 FIFO Control Register (FCR)

This register is used to enable the FIFOs, clear the FIFOs, set the receive FIFO trigger levels, and select the DMA mode.

#### 7.3.1 DMA mode

**Mode 0 (FCR bit 3 = 0):** Set and enable the interrupt for each single transmit or receive operation, and is similar to the 16C450 mode. Transmit Ready ( $\overline{\text{TXRDY}}$ ) will go to a logic 0 whenever an empty transmit space is available in the Transmit Holding Register (THR). Receive Ready ( $\overline{\text{RXRDY}}$ ) will go to a logic 0 whenever the Receive Holding Register (RHR) is loaded with a character.

**Mode 1 (FCR bit 3 = 1):** Set and enable the interrupt in a block mode operation. The transmit interrupt is set when the transmit FIFO is below the programmed trigger level. The receive interrupt is set when the receive FIFO fills to the programmed trigger level. However, the FIFO continues to fill regardless of the programmed level until the FIFO is full.  $\overline{\text{RXRDY}}$  remains a logic 0 as long as the FIFO fill level is above the programmed trigger level.

#### 7.3.2 FIFO mode

Table 10: FIFO Control Register bits description

Bit	Symbol	Description
7-6	FCR[7] (MSB), FCR[6] (LSB)	RCVR trigger. These bits are used to set the trigger level for the receive FIFO interrupt.  An interrupt is generated when the number of characters in the FIFO equals the programmed trigger level. However, the FIFO will continue to be loaded until it is full. Refer to Table 11.
5	FCR[5]	Logic 0 = 16-byte mode (normal default condition). Logic 1 = 64-byte mode.
4	FCR[4]	Reserved.
3	FCR[3]	DMA mode select.  Logic 0 = Set DMA mode '0' (normal default condition). Logic 1 = Set DMA mode '1'

**Transmit operation in mode '0':** When the SC16C750 is in the 16C450 mode (FIFOs disabled; FCR[0] = logic 0) or in the FIFO mode (FIFOs enabled; FCR[0] = logic 1; FCR[3] = logic 0), and when there are no characters in the transmit FIFO or transmit holding register, the  $\overline{\text{TXRDY}}$  pin will be a logic 0. Once active, the  $\overline{\text{TXRDY}}$  pin will go to a logic 1 after the first character is loaded into the transmit holding register.

**Receive operation in mode '0':** When the SC16C750 is in 16C450 mode, or in the FIFO mode (FCR[0] = logic 1; FCR[3] = logic 0) and there is at least one character in the receive FIFO, the  $\overline{\text{RXRDY}}$  pin will be a logic 0. Once active, the  $\overline{\text{RXRDY}}$  pin will go to a logic 1 when there are no more characters in the receiver.

Table 10: FIFO Control Register bits description...continued

Bit	Symbol	Description
		<p><b>Transmit operation in mode '1':</b> When the SC16C750 is in FIFO mode (FCR[0] = logic 1; FCR[3] = logic 1), the <math>\overline{\text{TXRDY}}</math> pin will be a logic 1 when the transmit FIFO is completely full. It will be a logic 0 when the trigger level has been reached.</p> <p><b>Receive operation in mode '1':</b> When the SC16C750 is in FIFO mode (FCR[0] = logic 1; FCR[3] = logic 1) and the trigger level has been reached, or a Receive Time-Out has occurred, the <math>\overline{\text{RXRDY}}</math> pin will go to a logic 0. Once activated, it will go to a logic 1 after there are no more characters in the FIFO.</p>
2	FCR[2]	<p>XMIT FIFO reset.</p> <p>Logic 0 = No FIFO transmit reset (normal default condition).</p> <p>Logic 1 = Clears the contents of the transmit FIFO and resets the FIFO counter logic (the transmit shift register is not cleared or altered). This bit will return to a logic 0 after clearing the FIFO.</p>
1	FCR[1]	<p>RCVR FIFO reset.</p> <p>Logic 0 = No FIFO receive reset (normal default condition).</p> <p>Logic 1 = Clears the contents of the receive FIFO and resets the FIFO counter logic (the receive shift register is not cleared or altered). This bit will return to a logic 0 after clearing the FIFO.</p>
0	FCR[0]	<p>FIFO enable.</p> <p>Logic 0 = Disable the transmit and receive FIFO (normal default condition).</p> <p>Logic 1 = Enable the transmit and receive FIFO. <b>This bit must be a '1' when other FCR bits are written to, or they will not be programmed.</b></p>

Table 11: RCVR trigger levels

FCR[7]	FCR[6]	RX FIFO trigger level (bytes)	
		16-byte operation	64-byte operation
0	0	1	1
0	1	4	16
1	0	8	32
1	1	14	56

## 7.4 Interrupt Status Register (ISR)

The SC16C750 provides six levels of prioritized interrupts to minimize external software interaction. The Interrupt Status Register (ISR) provides the user with six interrupt status bits. Performing a read cycle on the ISR will provide the user with the highest pending interrupt level to be serviced. No other interrupts are acknowledged until the pending interrupt is serviced. Whenever the interrupt status register is read, the interrupt status is cleared. However, it should be noted that only the current pending interrupt is cleared by the read. A lower level interrupt may be seen after re-reading the interrupt status bits. Table 12 “Interrupt source” shows the data values (bits 0-5) for the six prioritized interrupt levels and the interrupt sources associated with each of these interrupt levels.

**Table 12: Interrupt source**

Priority level	ISR[3]	ISR[2]	ISR[1]	ISR[0]	Source of the interrupt
1	0	1	1	0	LSR (Receiver Line Status Register)
2	0	1	0	0	RXRDY (Received Data Ready)
2	1	1	0	0	RXRDY (Receive Data time-out)
3	0	0	1	0	TXRDY (Transmitter Holding Register Empty)
4	0	0	0	0	MSR (Modem Status Register)

**Table 13: Interrupt Status Register bits description**

Bit	Symbol	Description
7-6	ISR[7-6]	FIFOs enabled. These bits are set to a logic 0 when the FIFO is not being used. They are set to a logic 1 when the FIFOs are enabled. Logic 0 or cleared = default condition.
5	ISR[5]	64-byte FIFO enable. Logic 0 = 16-byte operation. Logic 1 = 64-byte operation.
4	ISR[4]	Not used.
3-1	ISR[3-1]	INT priority bits 2-0. These bits indicate the source for a pending interrupt at interrupt priority levels 1, 2, and 3 (see Table 12). Logic 0 or cleared = default condition.
0	ISR[0]	INT status. Logic 0 = An interrupt is pending and the ISR contents may be used as a pointer to the appropriate interrupt service routine. Logic 1 = No interrupt pending (normal default condition).

## 7.5 Line Control Register (LCR)

The Line Control Register is used to specify the asynchronous data communication format. The word length, the number of stop bits, and the parity are selected by writing the appropriate bits in this register.

**Table 14: Line Control Register bits description**

Bit	Symbol	Description
7	LCR[7] <sup>[1]</sup>	<p>Divisor latch enable. The internal baud rate counter latch and Enhance Feature mode enable.</p> <p>Logic 0 = Divisor latch disabled (normal default condition).</p> <p>Logic 1 = Divisor latch and enhanced feature register enabled.</p>
6	LCR[6]	<p>Set break. When enabled, the Break control bit causes a break condition to be transmitted (the TX output is forced to a logic 0 state). This condition exists until disabled by setting LCR[6] to a logic 0.</p> <p>Logic 0 = no TX break condition (normal default condition).</p> <p>Logic 1 = forces the transmitter output (TX) to a logic 0 for alerting the remote receiver to a line break condition.</p>
5	LCR[5]	<p>Set parity. If the parity bit is enabled, LCR[5] selects the forced parity format. Programs the parity conditions (see Table 15).</p> <p>Logic 0 = parity is not forced (normal default condition).</p> <p>LCR[5] = logic 1 and LCR[4] = logic 0: parity bit is forced to a logical 1 for the transmit and receive data.</p> <p>LCR[5] = logic 1 and LCR[4] = logic 1: parity bit is forced to a logical 0 for the transmit and receive data.</p>
4	LCR[4]	<p>Even parity. If the parity bit is enabled with LCR[3] set to a logic 1, LCR[4] selects the even or odd parity format.</p> <p>Logic 0 = ODD Parity is generated by forcing an odd number of logic 1s in the transmitted data. The receiver must be programmed to check the same format (normal default condition).</p> <p>Logic 1 = EVEN Parity is generated by forcing an even number of logic 1s in the transmitted data. The receiver must be programmed to check the same format.</p>
3	LCR[3]	<p>Parity enable. Parity or no parity can be selected via this bit.</p> <p>Logic 0 = no parity (normal default condition).</p> <p>Logic 1 = a parity bit is generated during the transmission, receiver checks the data and parity for transmission errors.</p>
2	LCR[2]	<p>Stop bits. The length of stop bit is specified by this bit in conjunction with the programmed word length (see Table 16).</p> <p>Logic 0 or cleared = default condition.</p>
1-0	LCR[1-0]	<p>Word length bits 1, 0. These two bits specify the word length to be transmitted or received (see Table 17).</p> <p>Logic 0 or cleared = default condition.</p>

[1] When LCR[7] = 1, the general register set cannot be accessed until LCR[7] = 0.

Table 15: LCR[5] parity selection

LCR[5]	LCR[4]	LCR[3]	Parity selection
X	X	0	no parity
0	0	1	ODD parity
0	1	1	EVEN parity
1	0	1	force parity '1'
1	1	1	forced parity '0'

Table 16: LCR[2] stop bit length

LCR[2]	Word length	Stop bit length (bit times)
0	5, 6, 7, 8	1
1	5	1- $\frac{1}{2}$
1	6, 7, 8	2

Table 17: LCR[1-0] word length

LCR[1]	LCR[0]	Word length
0	0	5
0	1	6
1	0	7
1	1	8

## 7.6 Modem Control Register (MCR)

This register controls the interface with the modem or a peripheral device.

**Table 18: Modem Control Register bits description**

Bit	Symbol	Description
7	MCR[7]	Reserved. Set to 0.
6	MCR[6]	Reserved. Set to 0.
5	MCR[5]	Reserved. Set to 0.
4	MCR[4]	<p>Loop-back. Enable the local loop-back mode (diagnostics). In this mode the transmitter output (<math>\overline{TX}</math>) and the receiver input (<math>\overline{RX}</math>), <math>\overline{CTS}</math>, <math>\overline{DSR}</math>, <math>\overline{DCD}</math>, and <math>\overline{RI}</math> are disconnected from the SC16C750 I/O pins. Internally the modem data and control pins are connected into a loop-back data configuration (see Figure 5). In this mode, the receiver and transmitter interrupts remain fully operational. The Modem Control Interrupts are also operational, but the interrupts' sources are switched to the lower four bits of the Modem Control. Interrupts continue to be controlled by the IER register.</p> <p>Logic 0 = Disable loop-back mode (normal default condition). Logic 1 = Enable local loop-back mode (diagnostics).</p>
3	MCR[3]	<p><math>\overline{OUT2}</math>, INTx enable. Used to control the modem <math>\overline{DCD}</math> signal in the loop-back mode.</p> <p>Logic 0 = Forces INT output to the 3-State mode. In the loop-back mode, sets <math>\overline{OUT2}</math> (<math>\overline{DCD}</math>) internally to a logic 1. Logic 1 = Forces the INT output to the active mode. In the loop-back mode, sets <math>\overline{OUT2}</math> (<math>\overline{DCD}</math>) internally to a logic 0.</p>
2	MCR[2]	<p><math>\overline{OUT1}</math>. This bit is used in the Loop-back mode only. In the loop-back mode, this bit is used to write the state of the modem <math>\overline{RI}</math> interface signal via <math>\overline{OUT1}</math>.</p>
1	MCR[1]	<p><math>\overline{RTS}</math></p> <p>Logic 0 = Force <math>\overline{RTS}</math> output to a logic 1 (normal default condition). Logic 1 = Force <math>\overline{RTS}</math> output to a logic 0.</p>
0	MCR[0]	<p><math>\overline{DTR}</math></p> <p>Logic 0 = Force <math>\overline{DTR}</math> output to a logic 1 (normal default condition). Logic 1 = Force <math>\overline{DTR}</math> output to a logic 0.</p>



## 7.7 Line Status Register (LSR)

This register provides the status of data transfers between the SC16C750 and the CPU.

**Table 19: Line Status Register bits description**

Bit	Symbol	Description
7	LSR[7]	FIFO data error. Logic 0 = No error (normal default condition). Logic 1 = At least one parity error, framing error or break indication is in the current FIFO data. This bit is cleared when LSR register is read.
6	LSR[6]	THR and TSR empty. This bit is the Transmit Empty indicator. This bit is set to a logic 1 whenever the transmit holding register and the transmit shift register are both empty. It is reset to logic 0 whenever either the THR or TSR contains a data character. In the FIFO mode, this bit is set to '1' whenever the transmit FIFO and transmit shift register are both empty.
5	LSR[5]	THR empty. This bit is the Transmit Holding Register Empty indicator. This bit indicates that the UART is ready to accept a new character for transmission. In addition, this bit causes the UART to issue an interrupt to CPU when the THR interrupt enable is set. The THR bit is set to a logic 1 when a character is transferred from the transmit holding register into the transmitter shift register. The bit is reset to a logic 0 concurrently with the loading of the transmitter holding register by the CPU. In the FIFO mode, this bit is set when the transmit FIFO is empty; it is cleared when at least 1 byte is written to the transmit FIFO.
4	LSR[4]	Break interrupt. Logic 0 = No break condition (normal default condition). Logic 1 = The receiver received a break signal (RX was a logic 0 for one character frame time). In the FIFO mode, only one break character is loaded into the FIFO.
3	LSR[3]	Framing error. Logic 0 = No framing error (normal default condition). Logic 1 = Framing error. The receive character did not have a valid stop bit(s). In the FIFO mode, this error is associated with the character at the top of the FIFO.
2	LSR[2]	Parity error. Logic 0 = No parity error (normal default condition). Logic 1 = Parity error. The receive character does not have correct parity information and is suspect. In the FIFO mode, this error is associated with the character at the top of the FIFO.
1	LSR[1]	Overrun error. Logic 0 = No overrun error (normal default condition). Logic 1 = Overrun error. A data overrun error occurred in the receive shift register. This happens when additional data arrives while the FIFO is full. In this case, the previous data in the shift register is overwritten. Note that under this condition, the data byte in the receive shift register is not transferred into the FIFO, therefore the data in the FIFO is not corrupted by the error.

Table 19: Line Status Register bits description...continued

Bit	Symbol	Description
0	LSR[0]	Receive data ready.  Logic 0 = No data in receive holding register or FIFO (normal default condition).  Logic 1 = Data has been received and is saved in the receive holding register or FIFO.

## 7.8 Modem Status Register (MSR)

This register provides the current state of the control interface signals from the modem, or other peripheral device to which the SC16C750 is connected. Four bits of this register are used to indicate the changed information. These bits are set to a logic 1 whenever a control input from the modem changes state. These bits are set to a logic 0 whenever the CPU reads this register.

Table 20: Modem Status Register bits description

Bit	Symbol	Description
7	MSR[7]	Data Carrier Detect. $\overline{DCD}$ (Active-HIGH, logical 1). Normally this bit is the complement of the $\overline{DCD}$ input. In the loop-back mode this bit is equivalent to the OUT2 bit in the MCR register.
6	MSR[6]	Ring Indicator. RI (Active-HIGH, logical 1). Normally this bit is the complement of the $\overline{RI}$ input. In the loop-back mode this bit is equivalent to the OUT1 bit in the MCR register.
5	MSR[5]	Data Set Ready. DSR (Active-HIGH, logical 1). Normally this bit is the complement of the $\overline{DSR}$ input. In loop-back mode this bit is equivalent to the DTR bit in the MCR register.
4	MSR[4]	Clear To Send. CTS. $\overline{CTS}$ functions as hardware flow control signal input if it is enabled via EFR[7]. Flow control (when enabled) allows starting and stopping the transmissions based on the external modem $\overline{CTS}$ signal. A logic 1 at the $\overline{CTS}$ pin will stop SC16C750 transmissions as soon as current character has finished transmission. Normally MSR[4] is the complement of the $\overline{CTS}$ input. However, in the loop-back mode, this bit is equivalent to the RTS bit in the MCR register.
3	MSR[3]	$\Delta\overline{DCD}$ [1]  Logic 0 = No $\overline{DCD}$ change (normal default condition). Logic 1 = The $\overline{DCD}$ input to the SC16C750 has changed state since the last time it was read. A modem Status Interrupt will be generated.
2	MSR[2]	$\Delta\overline{RI}$ [1]  Logic 0 = No $\overline{RI}$ change (normal default condition). Logic 1 = The $\overline{RI}$ input to the SC16C750 has changed from a logic 0 to a logic 1. A modem Status Interrupt will be generated.

Table 20: Modem Status Register bits description...continued

Bit	Symbol	Description
1	MSR[1]	$\Delta\overline{DSR}$ [1] Logic 0 = No $\overline{DSR}$ change (normal default condition). Logic 1 = The $\overline{DSR}$ input to the SC16C750 has changed state since the last time it was read. A modem Status Interrupt will be generated.
0	MSR[0]	$\Delta\overline{CTS}$ [1] Logic 0 = No $\overline{CTS}$ change (normal default condition). Logic 1 = The $\overline{CTS}$ input to the SC16C750 has changed state since the last time it was read. A modem Status Interrupt will be generated.

[1] Whenever any MSR bit 0-3 is set to logic 1, a Modem Status Interrupt will be generated.

## 7.9 Scratchpad Register (SPR)

The SC16C750 provides a temporary data register to store 8 bits of user information.

## 7.10 Enhanced Feature Register (EFR)

Enhanced features are enabled or disabled using this register.

Table 21: Enhanced Feature Register bits description

Bit	Symbol	Description
7	EFR[7]	Automatic CTS flow control. Logic 0 = Automatic CTS flow control is disabled (normal default condition). Logic 1 = Enable Automatic CTS flow control. Transmission will stop when $\overline{CTS}$ goes to a logical 1. Transmission will resume when the $\overline{CTS}$ pin returns to a logical 0.
6	EFR[6]	Automatic RTS flow control. Automatic RTS may be used for hardware flow control by enabling EFR[6]. When Auto-RTS is selected, an interrupt will be generated when the receive FIFO is filled to the programmed trigger level and $\overline{RTS}$ will go to a logic 1 at the next trigger level. $\overline{RTS}$ will return to a logic 0 when data is unloaded below the next lower trigger level (programmed trigger level 1). The state of this register bit changes with the status of the hardware flow control. $\overline{RTS}$ functions normally when hardware flow control is disabled. 0 = Automatic RTS flow control is disabled (normal default condition). 1 = Enable Automatic RTS flow control.
5-0	EFR[5-0]	Reserved; set to 0.

## 7.11 SC16C750 external reset conditions

Table 22: Reset state for registers

Register	Reset state
IER	IER[7-0] = 0
ISR	ISR[7-1] = 0; ISR[0] = 1
LCR	LCR[7-0] = 0
MCR	MCR[7-0] = 0
LSR	LSR[7] = 0; LSR[6-5] = 1; LSR[4-0] = 0
MSR	MSR[7-4] = input signals; MSR[3-0] = 0
FCR	FCR[7-0] = 0
EFR	EFR[7-0] = 0

Table 23: Reset state for outputs

Output	Reset state
TX	HIGH
$\overline{\text{RTS}}$	HIGH
$\overline{\text{DTR}}$	HIGH
$\overline{\text{RXRDY}}$	HIGH (STD mode)
$\overline{\text{TXRDY}}$	LOW (STD mode)
INT	LOW (STD mode)

## 8. Limiting values

Table 24: Limiting values

In accordance with the Absolute Maximum Rating System (IEC 60134).

Symbol	Parameter	Conditions	Min	Max	Unit
$V_{\text{CC}}$	supply voltage		-	7	V
$V_{\text{n}}$	voltage at any pin		GND - 0.3	$V_{\text{CC}} + 0.3$	V
$T_{\text{amb}}$	operating temperature		-40	+85	°C
$T_{\text{stg}}$	storage temperature		-65	+150	°C
$P_{\text{tot(pack)}}$	total power dissipation per package		-	500	mW

## 9. Static characteristics

**Table 25: DC electrical characteristics**

$T_{amb} = -40\text{ }^{\circ}\text{C}$  to  $+85\text{ }^{\circ}\text{C}$ ;  $V_{CC} = 2.5\text{V}$ ,  $3.3\text{V}$  or  $5.0\text{V} \pm 10\%$ , unless otherwise specified.

Symbol	Parameter	Conditions	2.5 V		3.3 V		5.0 V		Unit
			Min	Max	Min	Max	Min	Max	
$V_{IL(CK)}$	LOW-level clock input voltage		-0.3	0.45	-0.3	0.6	-0.5	0.6	V
$V_{IH(CK)}$	HIGH-level clock input voltage		1.8	$V_{CC}$	2.4	$V_{CC}$	3.0	$V_{CC}$	V
$V_{IL}$	LOW-level input voltage		-0.3	0.65	-0.3	0.8	-0.5	0.8	V
$V_{IH}$	HIGH-level input voltage		1.6	-	2.0	-	2.2	$V_{CC}$	V
$V_{OL}$	LOW-level output voltage on all outputs <sup>[1]</sup>	$I_{OL} = 5\text{ mA}$ (databus)	-	-	-	-	-	0.4	V
		$I_{OL} = 4\text{ mA}$ (other outputs)	-	-	-	0.4	-	-	V
		$I_{OL} = 2\text{ mA}$ (databus)	-	0.4	-	-	-	-	V
		$I_{OL} = 1.6\text{ mA}$ (other outputs)	-	0.4	-	-	-	-	V
$V_{OH}$	HIGH-level output voltage	$I_{OH} = -5\text{ mA}$ (databus)	-	-	-	-	2.4	-	V
		$I_{OH} = -1\text{ mA}$ (other outputs)	-	-	2.0	-	-	-	V
		$I_{OH} = -800\text{ }\mu\text{A}$ (databus)	1.85	-	-	-	-	-	V
		$I_{OH} = -400\text{ }\mu\text{A}$ (other outputs)	1.85	-	-	-	-	-	V
$I_{LIL}$	LOW-level input leakage current		-	$\pm 10$	-	$\pm 10$	-	$\pm 10$	$\mu\text{A}$
$I_{CL}$	clock leakage		-	$\pm 30$	-	$\pm 30$	-	$\pm 30$	$\mu\text{A}$
$I_{CC}$	average power supply current		-	3.5	-	4.5	-	4.5	mA
$C_i$	input capacitance		-	5	-	5	-	5	pF
$R_{pu(int)}$	internal pull-up resistance <sup>[2]</sup>		500	-	500	-	500	-	k $\Omega$

[1] Except for  $x_2$ ,  $V_{OL} = 1\text{ V}$  typically.

[2] Refer to [Table 2 "Pin description" on page 5](#) for a listing of pins having internal pull-up resistors.

## 10. Dynamic characteristics

**Table 26: AC electrical characteristics**
 $T_{amb} = -40^{\circ}\text{C to } +85^{\circ}\text{C}; V_{CC} = 2.5\text{ V, } 3.3\text{ V or } 5\text{ V} \pm 10\%, \text{ unless otherwise specified.}$ 

Symbol	Parameter	Conditions	2.5 V		3.3 V		5.0 V		Unit
			Min	Max	Min	Max	Min	Max	
$t_{1w}, t_{2w}$	clock pulse duration		15	-	13	-	10	-	ns
$t_{3w}$	oscillator/clock frequency	[1]	-	16	-	32	-	48	MHz
$t_{4w}$	address strobe width		45	-	35	-	25	-	ns
$t_{5s}$	address set-up time		5	-	5	-	1	-	ns
$t_{5h}$	address hold time		5	-	5	-	5	-	ns
$t_{6s}$	chip select set-up time to $\overline{\text{AS}}$		10	-	5	-	0	-	ns
$t_{6h}$	address hold time		0	-	0	-	0	-	ns
$t_{6s'}$	address set-up time	[2]	10	-	10	-	5	-	ns
$t_{6h}$	chip select hold time		0	-	0	-	0	-	ns
$t_{7d}$	$\overline{\text{IOR}}$ delay from chip select		10	-	10	-	10	-	ns
$t_{7w}$	$\overline{\text{IOR}}$ strobe width	25 pF load	77	-	26	-	23	-	ns
$t_{7h}$	chip select hold time from $\overline{\text{IOR}}$		0	-	0	-	0	-	ns
$t_{7h'}$	address hold time	[2]	5	-	5	-	5	-	ns
$t_{8d}$	$\overline{\text{IOR}}$ delay from address		10	-	10	-	10	-	ns
$t_{9d}$	read cycle delay	25 pF load	20	-	20	-	20	-	ns
$t_{11d}$	$\overline{\text{IOR}}$ to $\overline{\text{DIS}}$ delay	25 pF load	-	100	-	35	-	30	ns
$t_{12d}$	delay from $\overline{\text{IOR}}$ to data	25 pF load	-	77	-	26	-	23	ns
$t_{12h}$	data disable time	25 pF load	-	15	-	15	-	15	ns
$t_{13d}$	$\overline{\text{IOW}}$ delay from chip select		10	-	10	-	10	-	ns
$t_{13w}$	$\overline{\text{IOW}}$ strobe width	[3]	20	-	20	-	15	-	ns
$t_{13h}$	chip select hold time from $\overline{\text{IOW}}$		0	-	0	-	0	-	ns
$t_{14d}$	$\overline{\text{IOW}}$ delay from address		10	-	10	-	10	-	ns
$t_{15d}$	write cycle delay	[4]	25	-	25	-	20	-	ns
$t_{16s}$	data set-up time		20	-	20	-	15	-	ns
$t_{16h}$	data hold time		15	-	5	-	5	-	ns
$t_{17d}$	delay from $\overline{\text{IOW}}$ to output	25 pF load	-	100	-	33	-	29	ns
$t_{18d}$	delay to set interrupt from Modem input	25 pF load	-	100	-	24	-	23	ns
$t_{19d}$	delay to reset interrupt from $\overline{\text{IOR}}$	25 pF load	-	100	-	24	-	23	ns
$t_{20d}$	delay from stop to set interrupt		-	1	-	1	-	1	$R_{clk}$
$t_{21d}$	delay from $\overline{\text{IOR}}$ to reset interrupt	25 pF load	-	100	-	29	-	28	ns
$t_{22d}$	delay from start to set interrupt		-	100	-	45	-	40	ns
$t_{23d}$	delay from $\overline{\text{IOW}}$ to transmit start		8	24	8	24	8	24	$R_{clk}$
$t_{24d}$	delay from $\overline{\text{IOW}}$ to reset interrupt		-	100	-	45	-	40	ns
$t_{25d}$	delay from stop to set $\overline{\text{RXRDY}}$		-	1	-	1	-	1	$R_{clk}$
$t_{26d}$	delay from $\overline{\text{IOR}}$ to reset $\overline{\text{RXRDY}}$		-	100	-	45	-	40	ns
$t_{27d}$	delay from $\overline{\text{IOW}}$ to set $\overline{\text{TXRDY}}$		-	100	-	45	-	40	ns

Table 26: AC electrical characteristics...continued

$T_{amb} = -40^{\circ}\text{C}$  to  $+85^{\circ}\text{C}$ ;  $V_{CC} = 2.5\text{ V}$ ,  $3.3\text{ V}$  or  $5\text{ V} \pm 10\%$ , unless otherwise specified.

Symbol	Parameter	Conditions	2.5 V		3.3 V		5.0 V		Unit
			Min	Max	Min	Max	Min	Max	
$t_{28d}$	delay from start to reset TXRDY		-	8	-	8	-	8	$R_{clk}$
$t_{RESET}$	Reset pulse width		100	-	40	-	40	-	ns
N	baud rate divisor		1	$2^{16} - 1$	1	$2^{16} - 1$	1	$2^{16} - 1$	$R_{clk}$

[1] Applies to external clock, crystal oscillator max 24 MHz.

[2] Applicable only when  $\overline{AS}$  is tied LOW.

[3] 
$$\overline{IOW}_{strobe_{max}} = \frac{1}{2(\text{Baudrate}_{max})}$$

= 333 ns (for  $\text{Baudrate}_{max} = 1.5\text{ Mbits/s}$ )

= 1  $\mu\text{s}$  (for  $\text{Baudrate}_{max} = 460.8\text{ kbits/s}$ )

= 4  $\mu\text{s}$  (for  $\text{Baudrate}_{max} = 115.2\text{ kbits/s}$ )

[4] When in **both** DMA mode 0 **and** FIFO enable mode, the write cycle delay should be larger than one  $x_1$  clock cycle.

### 10.1 Timing diagrams

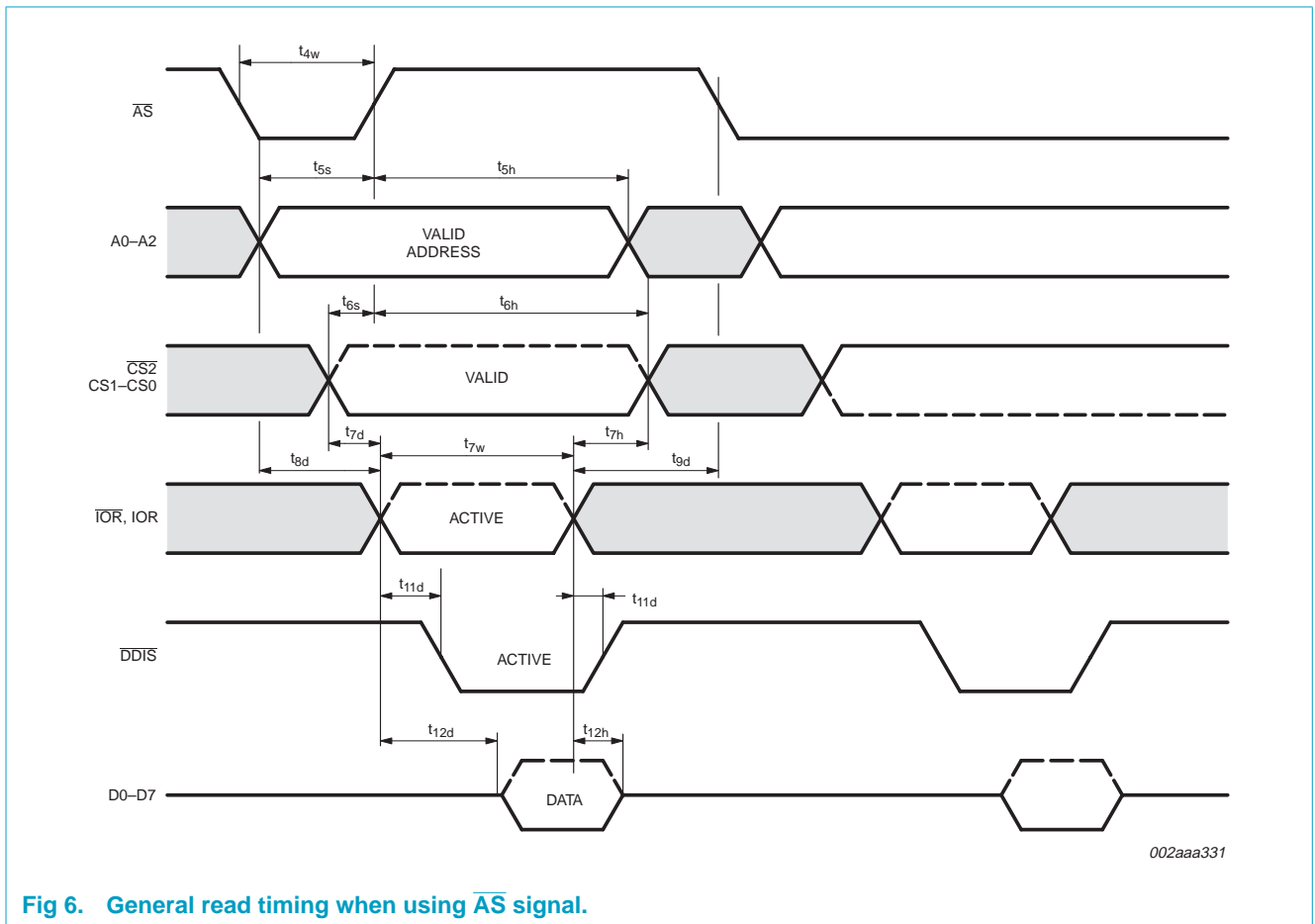

Fig 6. General read timing when using  $\overline{AS}$  signal.

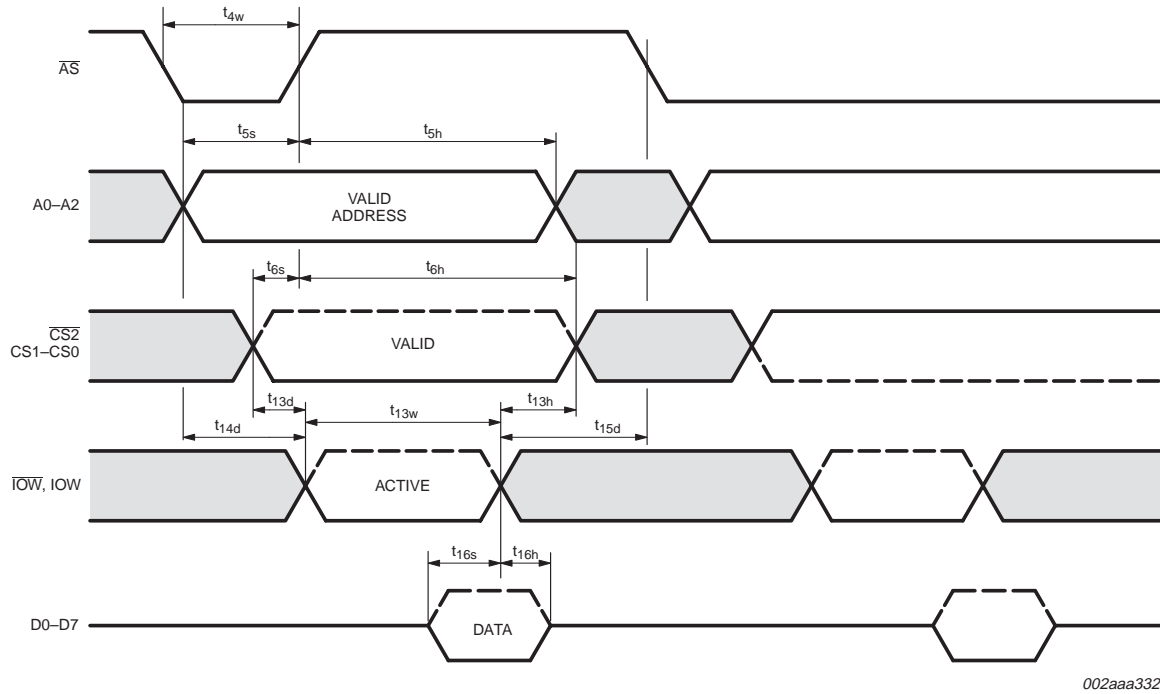

Fig 7. General write timing when using  $\overline{AS}$  signal.

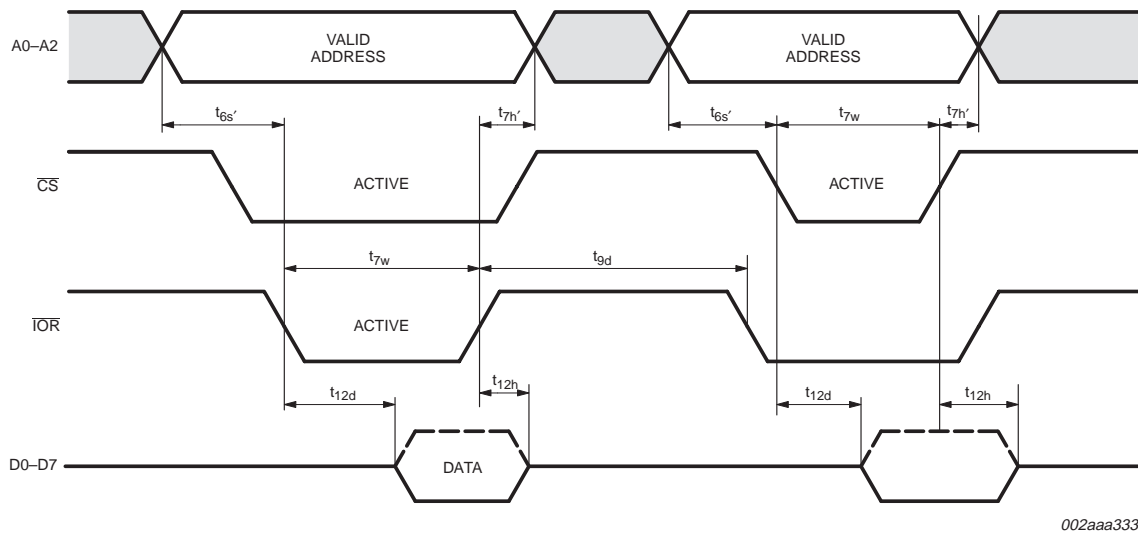
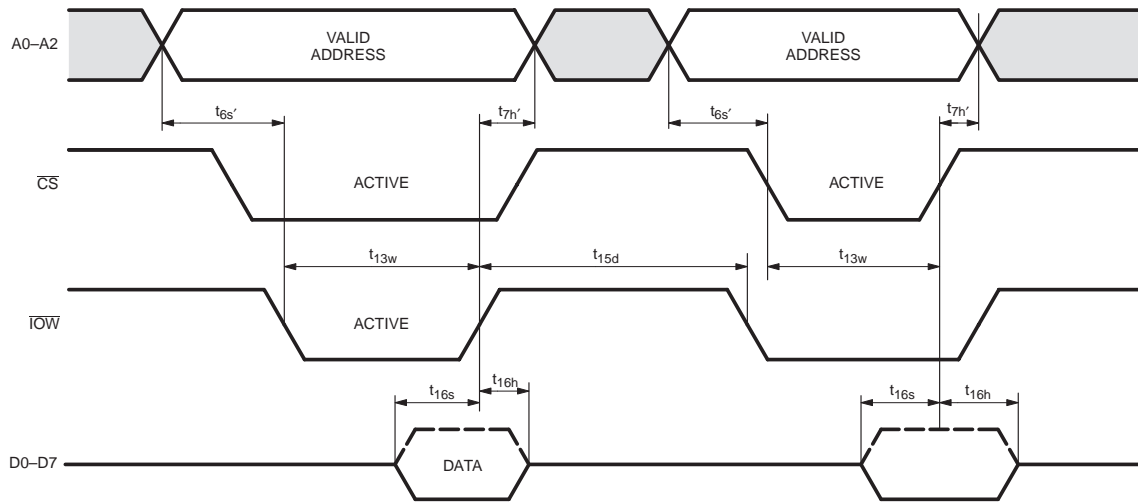

Fig 8. General read timing when  $\overline{AS}$  is tied to GND.





002aaa334

Fig 9. General write timing when  $\overline{AS}$  is tied to GND.

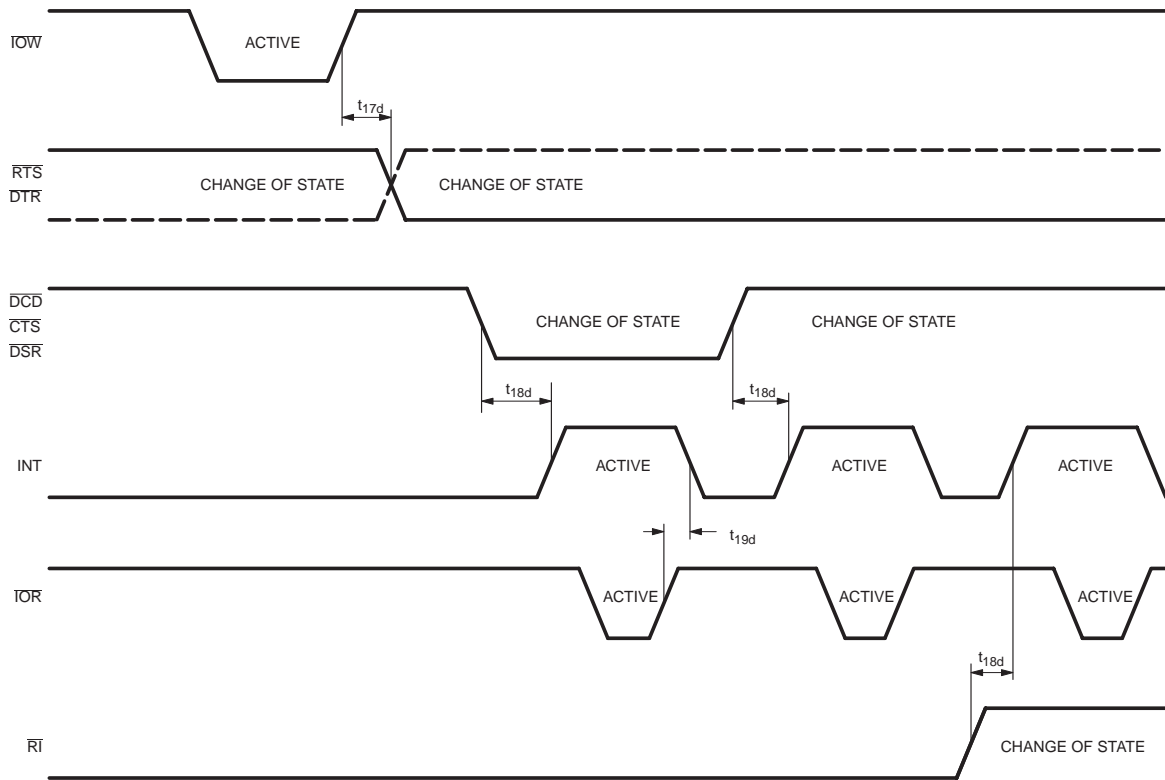

002aaa111

Fig 10. Modem input/output timing.

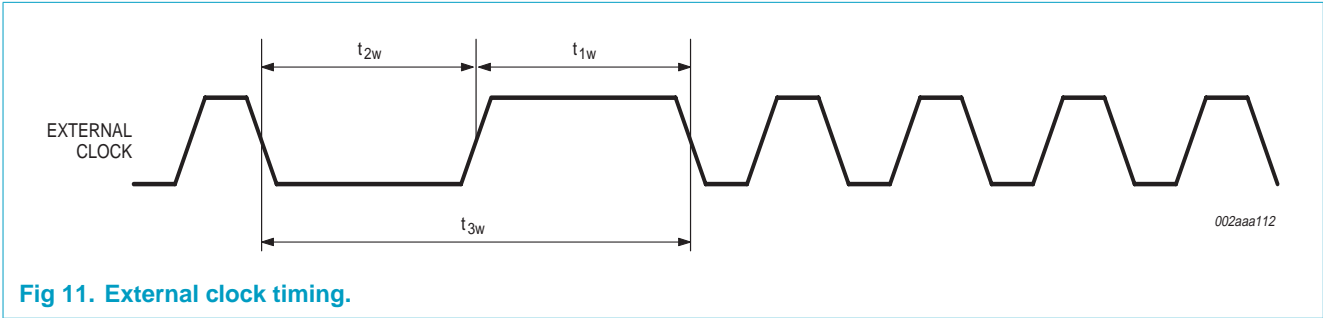

Fig 11. External clock timing.

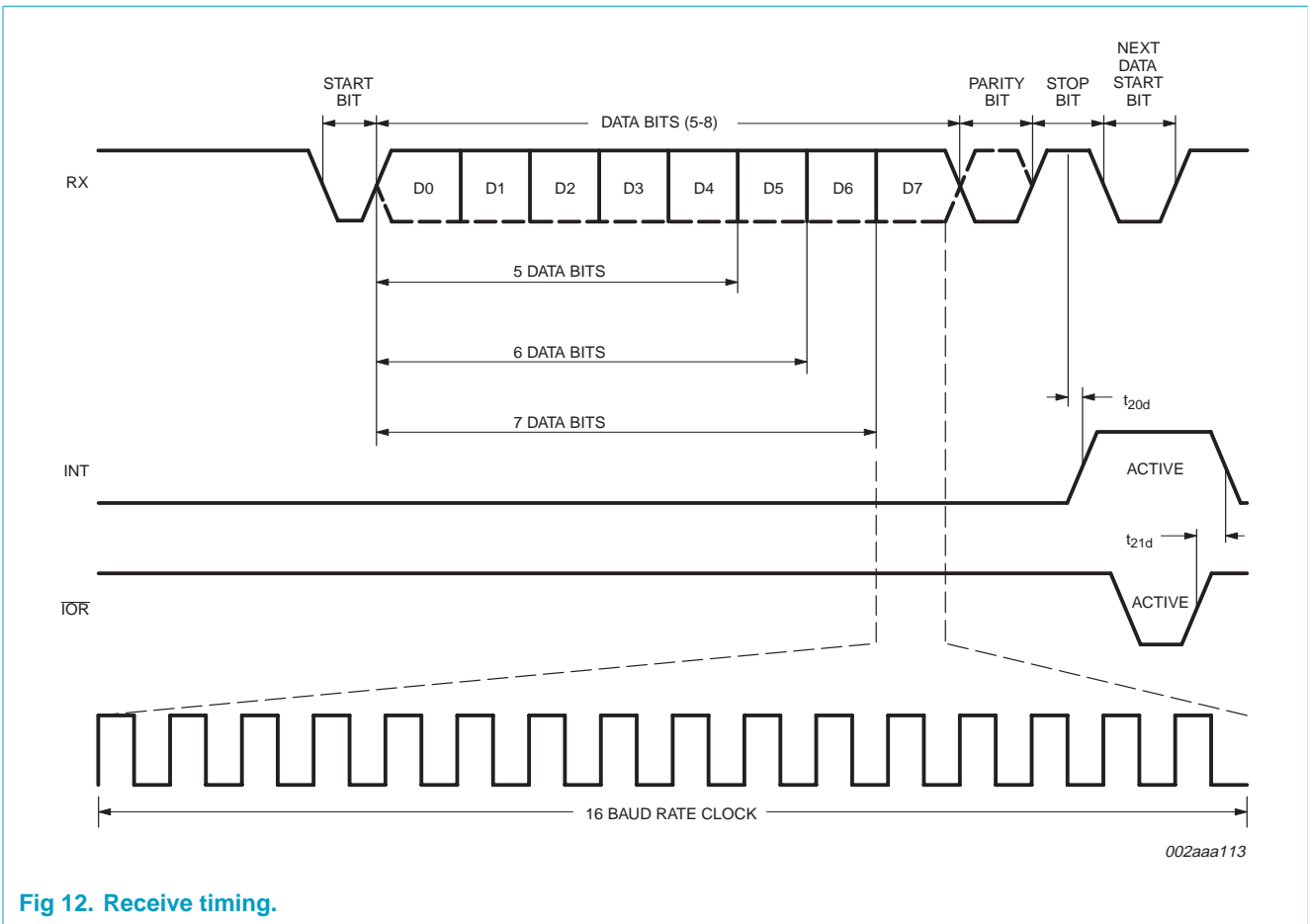

Fig 12. Receive timing.

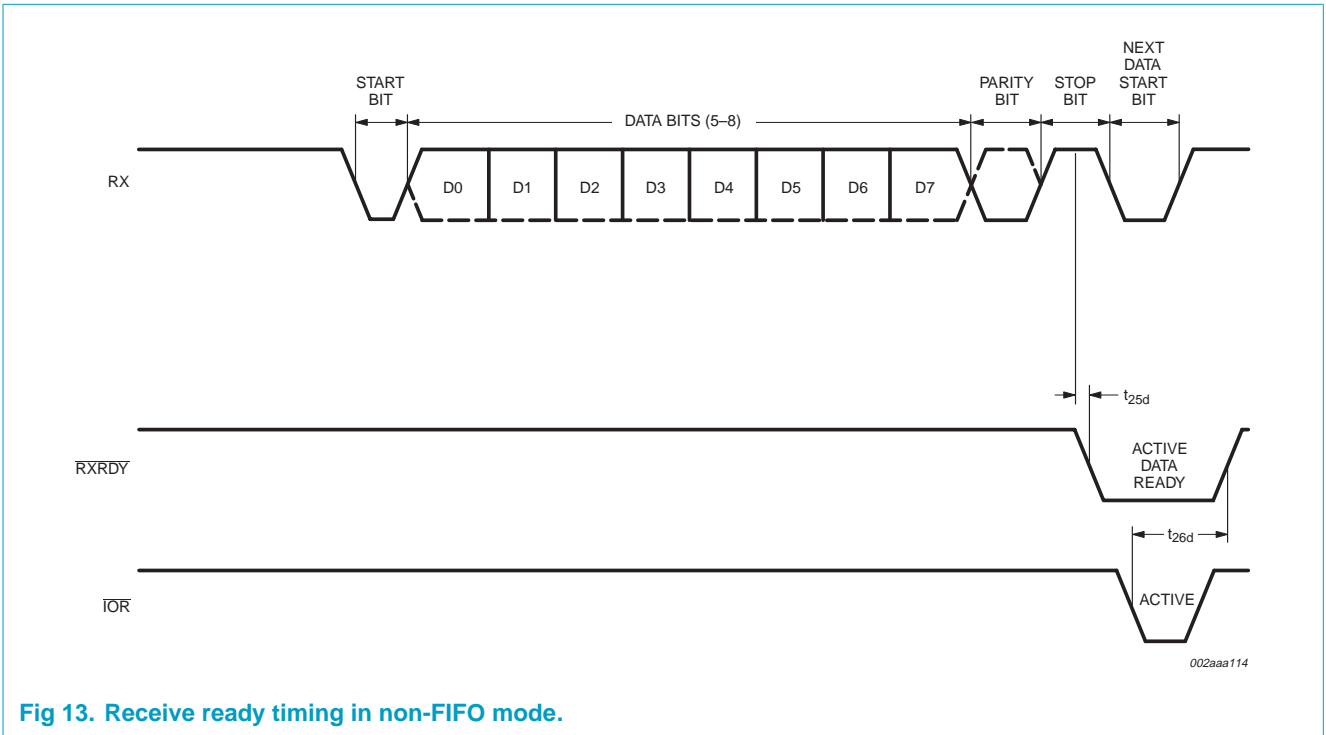

Fig 13. Receive ready timing in non-FIFO mode.

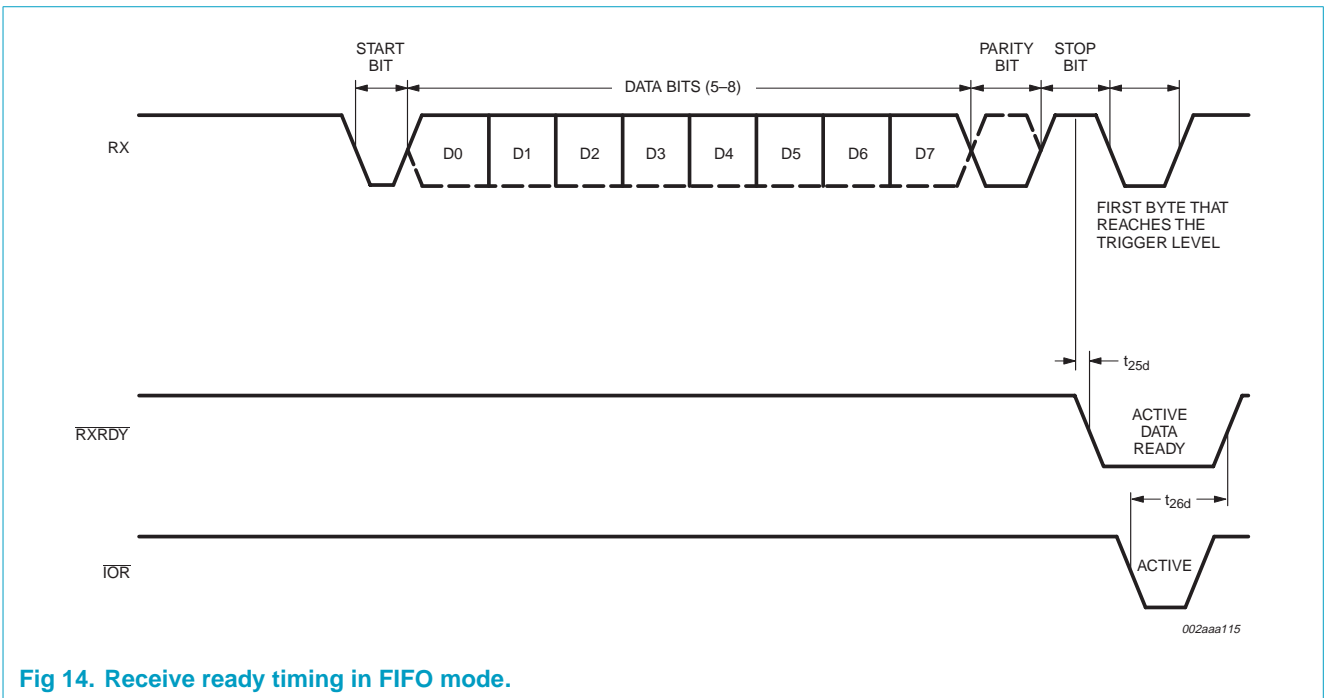

Fig 14. Receive ready timing in FIFO mode.

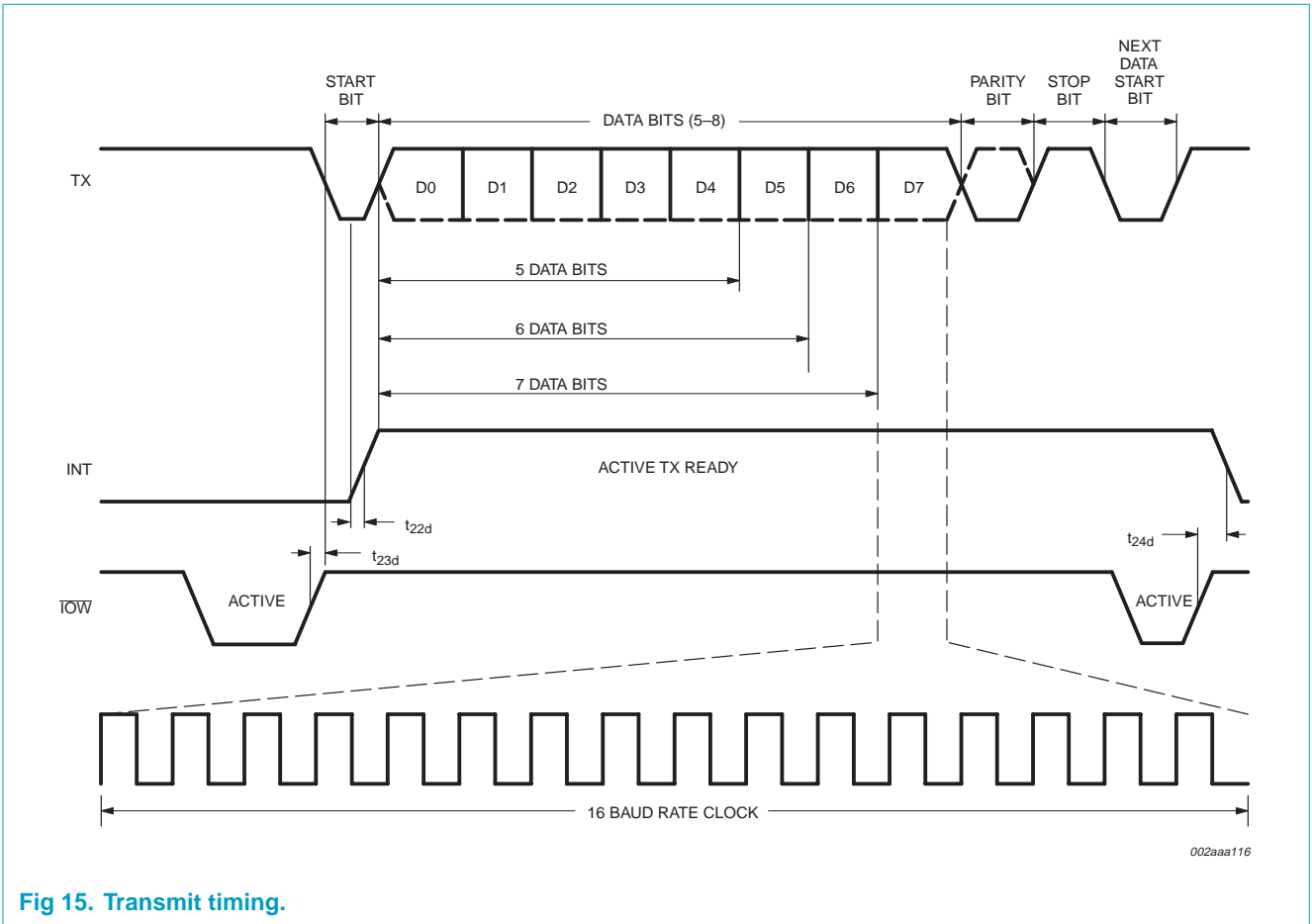

Fig 15. Transmit timing.

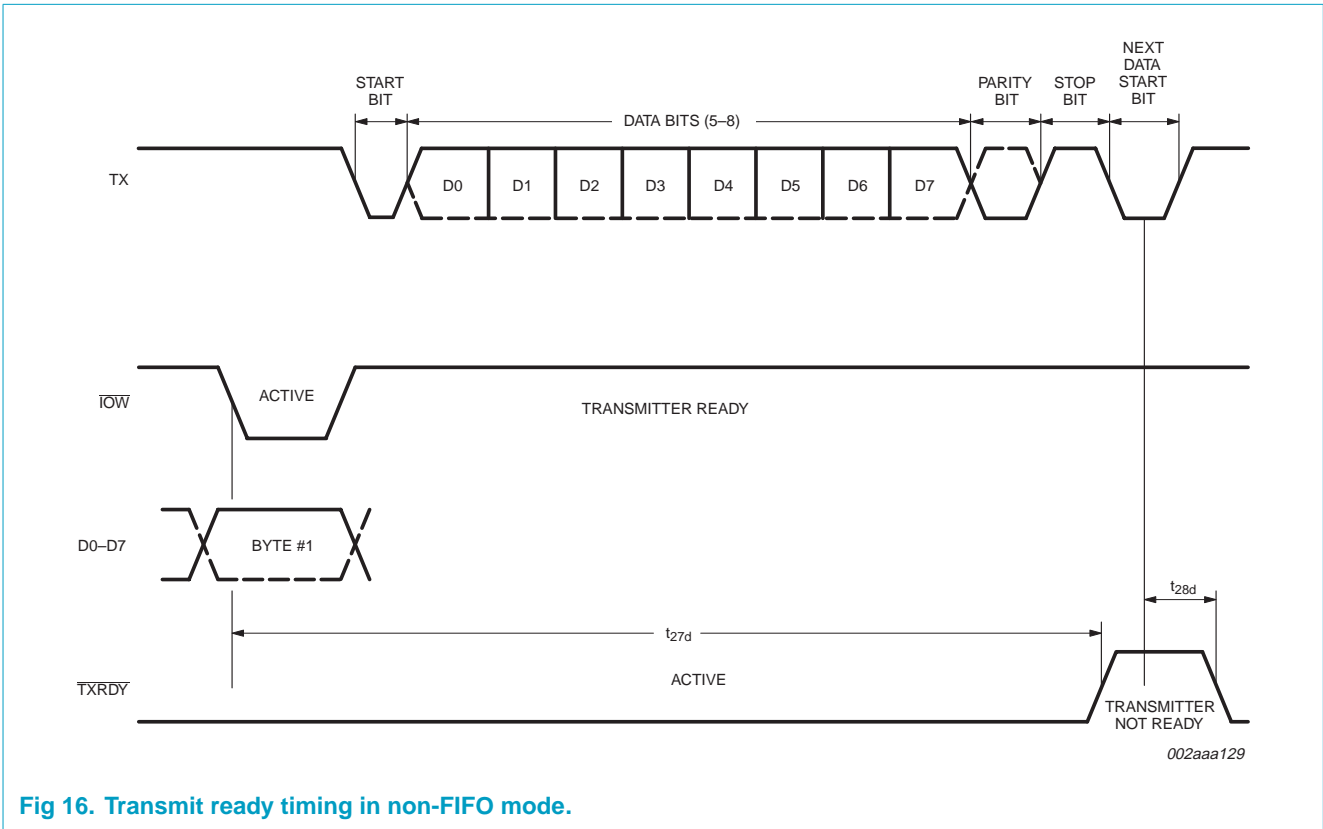

Fig 16. Transmit ready timing in non-FIFO mode.

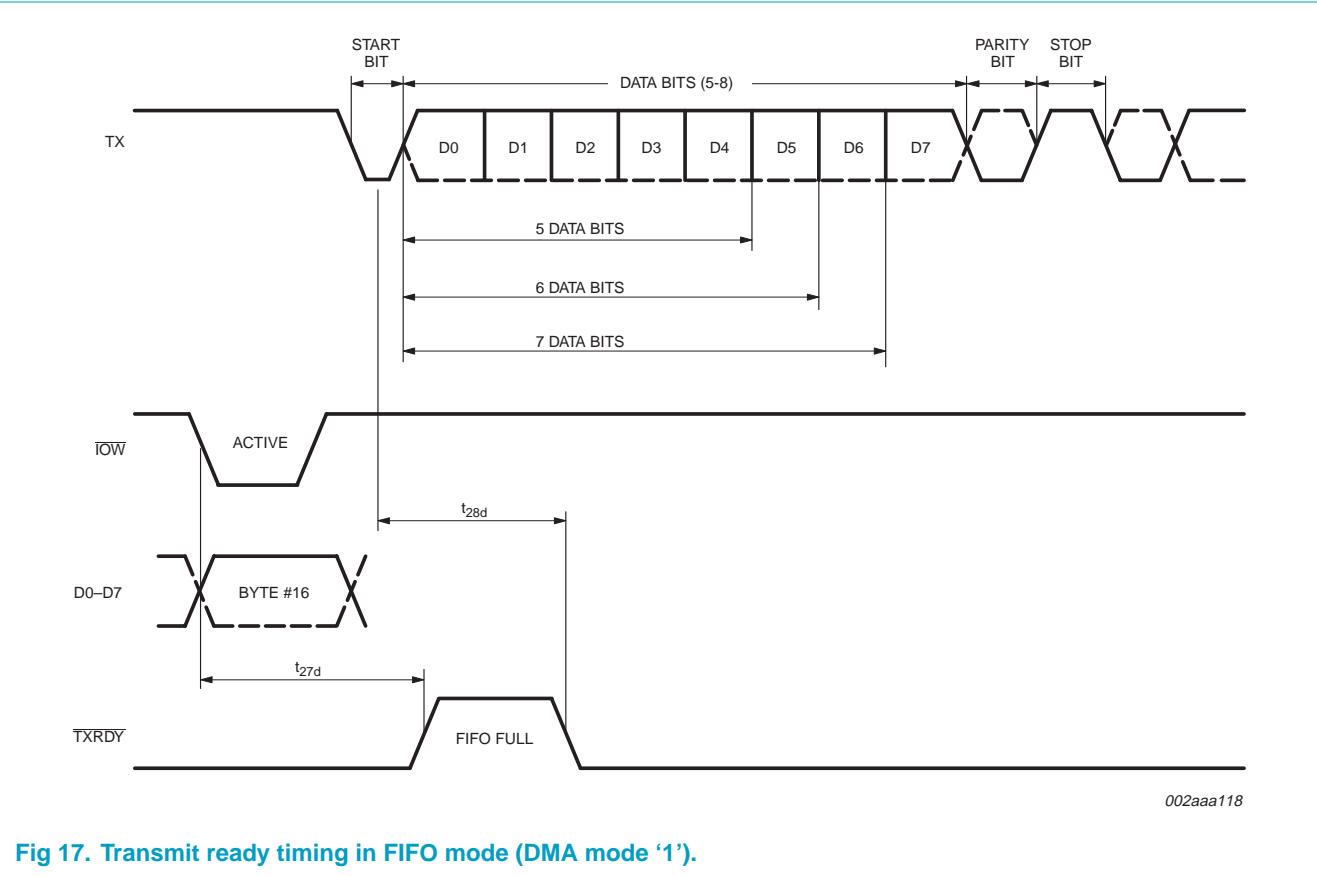

Fig 17. Transmit ready timing in FIFO mode (DMA mode '1').

### 11. Package outline

PLCC44: plastic leaded chip carrier; 44 leads

SOT187-2

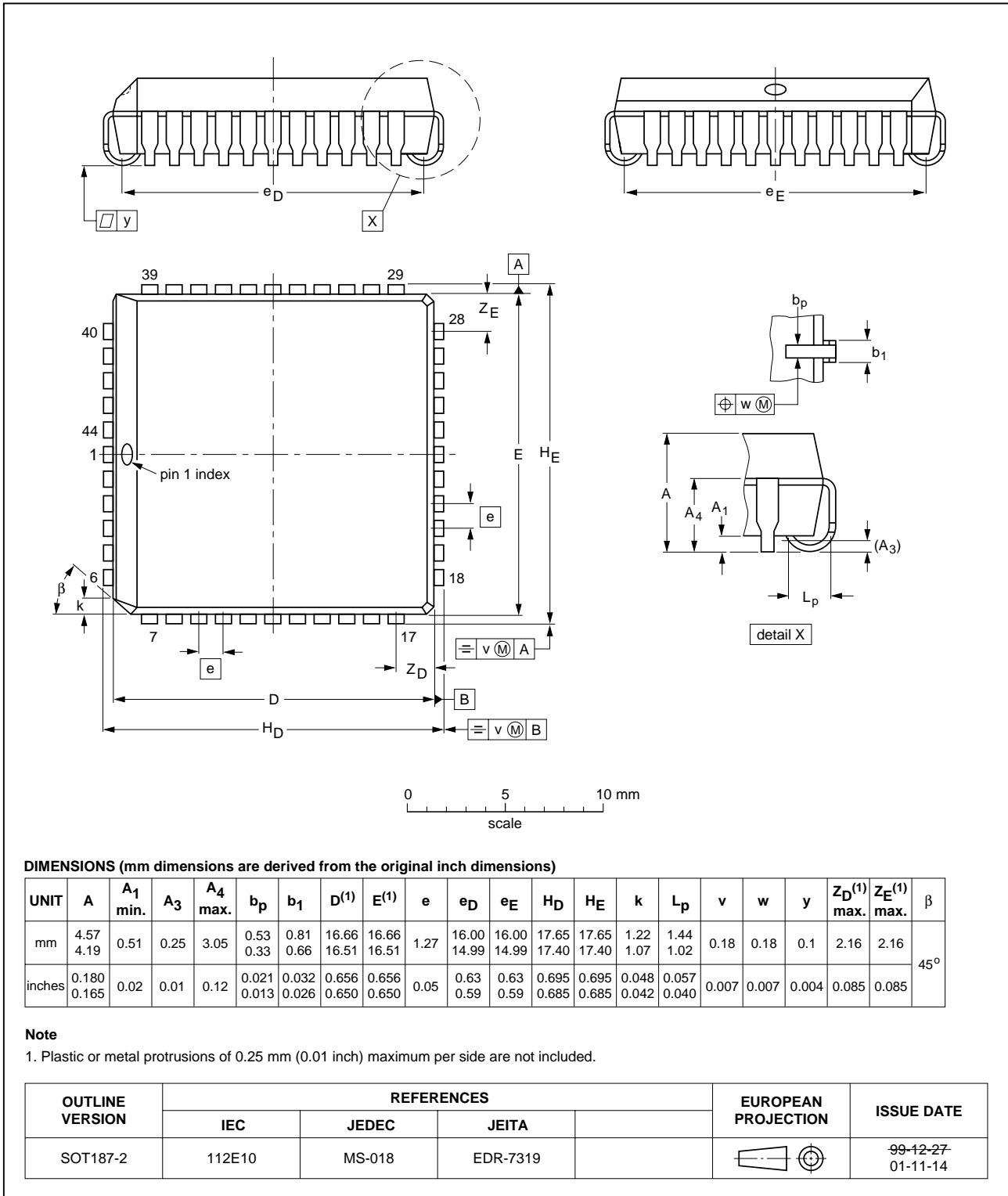

Fig 18. PLCC44 (SOT187-2).

LQFP64: plastic low profile quad flat package; 64 leads; body 10 x 10 x 1.4 mm

SOT314-2

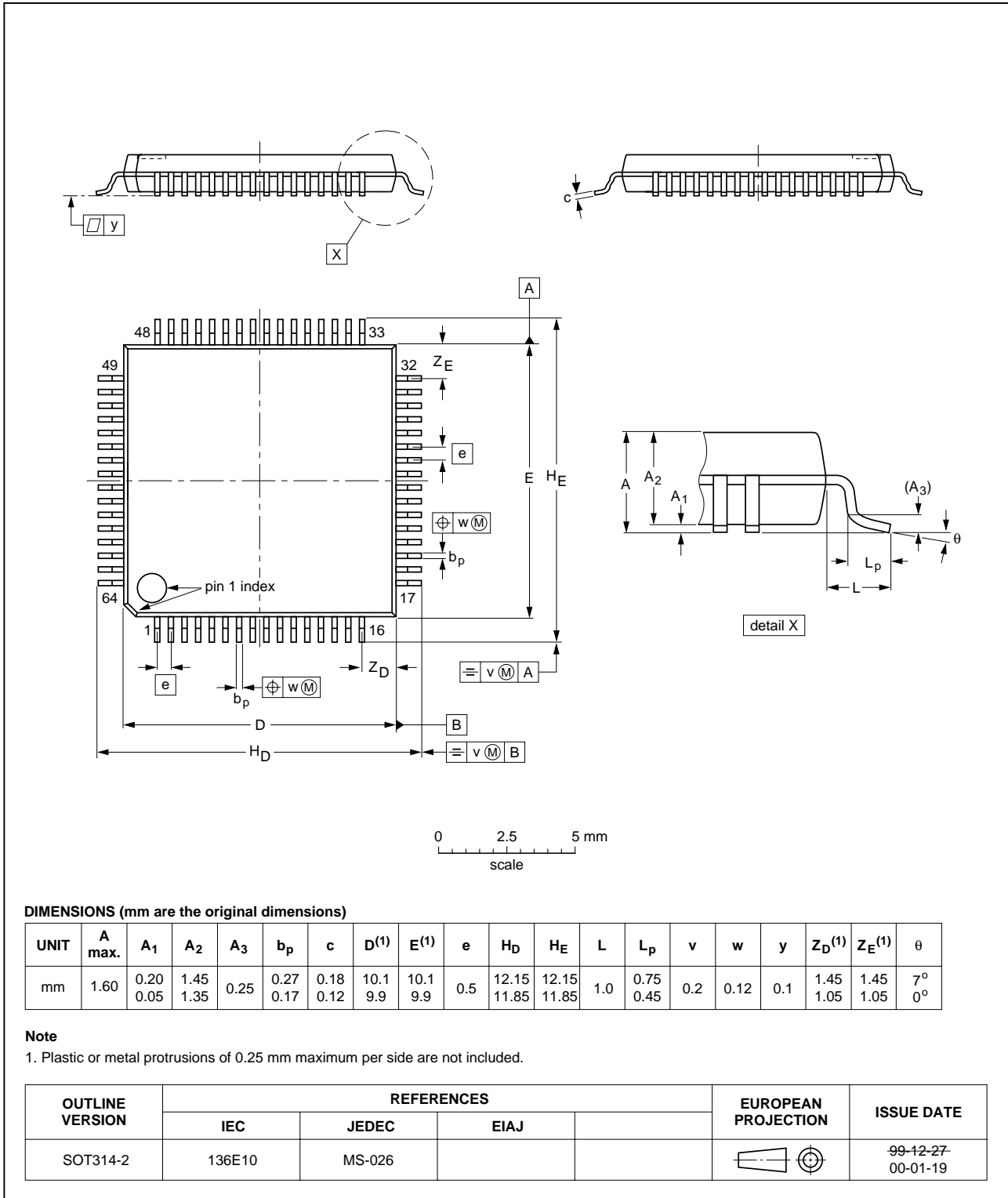

Fig 19. LQFP64 (SOT314-2).



## 12. Soldering

### 12.1 Introduction to soldering surface mount packages

This text gives a very brief insight to a complex technology. A more in-depth account of soldering ICs can be found in our *Data Handbook IC26; Integrated Circuit Packages* (document order number 9398 652 90011).

There is no soldering method that is ideal for all surface mount IC packages. Wave soldering can still be used for certain surface mount ICs, but it is not suitable for fine pitch SMDs. In these situations reflow soldering is recommended.

### 12.2 Reflow soldering

Reflow soldering requires solder paste (a suspension of fine solder particles, flux and binding agent) to be applied to the printed-circuit board by screen printing, stencilling or pressure-syringe dispensing before package placement.

Several methods exist for reflowing; for example, convection or convection/infrared heating in a conveyor type oven. Throughput times (preheating, soldering and cooling) vary between 100 and 200 seconds depending on heating method.

Typical reflow peak temperatures range from 215 to 250 °C. The top-surface temperature of the packages should preferably be kept:

- below 220 °C for all the BGA packages and packages with a thickness  $\geq 2.5$ mm and packages with a thickness  $<2.5$  mm and a volume  $\geq 350$  mm<sup>3</sup> so called thick/large packages
- below 235 °C for packages with a thickness  $<2.5$  mm and a volume  $<350$  mm<sup>3</sup> so called small/thin packages.

### 12.3 Wave soldering

Conventional single wave soldering is not recommended for surface mount devices (SMDs) or printed-circuit boards with a high component density, as solder bridging and non-wetting can present major problems.

To overcome these problems the double-wave soldering method was specifically developed.

If wave soldering is used the following conditions must be observed for optimal results:

- Use a double-wave soldering method comprising a turbulent wave with high upward pressure followed by a smooth laminar wave.
- For packages with leads on two sides and a pitch (e):
  - larger than or equal to 1.27 mm, the footprint longitudinal axis is **preferred** to be parallel to the transport direction of the printed-circuit board;
  - smaller than 1.27 mm, the footprint longitudinal axis **must** be parallel to the transport direction of the printed-circuit board.

The footprint must incorporate solder thieves at the downstream end.

- For packages with leads on four sides, the footprint must be placed at a 45° angle to the transport direction of the printed-circuit board. The footprint must incorporate solder thieves downstream and at the side corners.

During placement and before soldering, the package must be fixed with a droplet of adhesive. The adhesive can be applied by screen printing, pin transfer or syringe dispensing. The package can be soldered after the adhesive is cured.

Typical dwell time is 4 seconds at 250 °C. A mildly-activated flux will eliminate the need for removal of corrosive residues in most applications.

## 12.4 Manual soldering

Fix the component by first soldering two diagonally-opposite end leads. Use a low voltage (24 V or less) soldering iron applied to the flat part of the lead. Contact time must be limited to 10 seconds at up to 300 °C.

When using a dedicated tool, all other leads can be soldered in one operation within 2 to 5 seconds between 270 and 320 °C.

## 12.5 Package related soldering information

**Table 27: Suitability of surface mount IC packages for wave and reflow soldering methods**

Package <sup>[1]</sup>	Soldering method	
	Wave	Reflow <sup>[2]</sup>
BGA, LBGA, LFBGA, SQFP, TFBGA, VFBGA	not suitable	suitable
DHVQFN, HBCC, HBGA, HLQFP, HSQFP, HSOP, HTQFP, HTSSOP, HVQFN, HVSON, SMS	not suitable <sup>[3]</sup>	suitable
PLCC <sup>[4]</sup> , SO, SOJ	suitable	suitable
LQFP, QFP, TQFP	not recommended <sup>[4][5]</sup>	suitable
SSOP, TSSOP, VSO, VSSOP	not recommended <sup>[6]</sup>	suitable

- [1] For more detailed information on the BGA packages refer to the *(LF)BGA Application Note* (AN01026); order a copy from your Philips Semiconductors sales office.
- [2] All surface mount (SMD) packages are moisture sensitive. Depending upon the moisture content, the maximum temperature (with respect to time) and body size of the package, there is a risk that internal or external package cracks may occur due to vaporization of the moisture in them (the so called popcorn effect). For details, refer to the Drypack information in the *Data Handbook IC26; Integrated Circuit Packages; Section: Packing Methods*.
- [3] These packages are not suitable for wave soldering. On versions with the heatsink on the bottom side, the solder cannot penetrate between the printed-circuit board and the heatsink. On versions with the heatsink on the top side, the solder might be deposited on the heatsink surface.
- [4] If wave soldering is considered, then the package must be placed at a 45° angle to the solder wave direction. The package footprint must incorporate solder thieves downstream and at the side corners.
- [5] Wave soldering is suitable for LQFP, QFP and TQFP packages with a pitch (e) larger than 0.8 mm; it is definitely not suitable for packages with a pitch (e) equal to or smaller than 0.65 mm.
- [6] Wave soldering is suitable for SSOP and TSSOP packages with a pitch (e) equal to or larger than 0.65 mm; it is definitely not suitable for packages with a pitch (e) equal to or smaller than 0.5 mm.

## 13. Revision history

Table 28: Revision history

Rev	Date	CPCN	Description
03	20030314	-	<b>Product data (9397 750 11203); ECN 853-2367 29619 of 07 March 2003.</b> Modifications: <ul style="list-style-type: none"><li>• <a href="#">Section 6.5 on page 12</a>, second paragraph: delete “(parallel resonant/22-33 pF load)”.</li><li>• <a href="#">Figure 4 on page 12</a>: capacitors’ values changed to 68 pF.</li><li>• <a href="#">Table 18 on page 24</a>, description of MCR[3]: change “INTA-INTD outputs” to “INT output” and remove references to “16 mode”.</li></ul>
02	20021211	-	<b>Product data (9397 750 10797); ECN 853-2367 29261 of 06 December 2002.</b>
01	20020904	-	<b>Product data (9397 750 10149); ECN 853-2367 28865 of 04 September 2002.</b>

## 14. Data sheet status

Level	Data sheet status <sup>[1]</sup>	Product status <sup>[2],[3]</sup>	Definition
I	Objective data	Development	This data sheet contains data from the objective specification for product development. Philips Semiconductors reserves the right to change the specification in any manner without notice.
II	Preliminary data	Qualification	This data sheet contains data from the preliminary specification. Supplementary data will be published at a later date. Philips Semiconductors reserves the right to change the specification without notice, in order to improve the design and supply the best possible product.
III	Product data	Production	This data sheet contains data from the product specification. Philips Semiconductors reserves the right to make changes at any time in order to improve the design, manufacturing and supply. Relevant changes will be communicated via a Customer Product/Process Change Notification (CPCN).

[1] Please consult the most recently issued data sheet before initiating or completing a design.

[2] The product status of the device(s) described in this data sheet may have changed since this data sheet was published. The latest information is available on the Internet at URL <http://www.semiconductors.philips.com>.

[3] For data sheets describing multiple type numbers, the highest-level product status determines the data sheet status.

## 15. Definitions

**Short-form specification** — The data in a short-form specification is extracted from a full data sheet with the same type number and title. For detailed information see the relevant data sheet or data handbook.

**Limiting values definition** — Limiting values given are in accordance with the Absolute Maximum Rating System (IEC 60134). Stress above one or more of the limiting values may cause permanent damage to the device. These are stress ratings only and operation of the device at these or at any other conditions above those given in the Characteristics sections of the specification is not implied. Exposure to limiting values for extended periods may affect device reliability.

**Application information** — Applications that are described herein for any of these products are for illustrative purposes only. Philips Semiconductors make no representation or warranty that such applications will be suitable for the specified use without further testing or modification.

## 16. Disclaimers

**Life support** — These products are not designed for use in life support appliances, devices, or systems where malfunction of these products can reasonably be expected to result in personal injury. Philips Semiconductors customers using or selling these products for use in such applications do so at their own risk and agree to fully indemnify Philips Semiconductors for any damages resulting from such application.

**Right to make changes** — Philips Semiconductors reserves the right to make changes in the products - including circuits, standard cells, and/or software - described or contained herein in order to improve design and/or performance. When the product is in full production (status 'Production'), relevant changes will be communicated via a Customer Product/Process Change Notification (CPCN). Philips Semiconductors assumes no responsibility or liability for the use of any of these products, conveys no licence or title under any patent, copyright, or mask work right to these products, and makes no representations or warranties that these products are free from patent, copyright, or mask work right infringement, unless otherwise specified.

## Contact information

For additional information, please visit <http://www.semiconductors.philips.com>.

For sales office addresses, send e-mail to: [sales.addresses@www.semiconductors.philips.com](mailto:sales.addresses@www.semiconductors.philips.com).

Fax: +31 40 27 24825

## Contents

<b>1</b>	<b>General description</b> . . . . .	<b>1</b>	<b>8</b>	<b>Limiting values</b> . . . . .	<b>28</b>
<b>2</b>	<b>Features</b> . . . . .	<b>1</b>	<b>9</b>	<b>Static characteristics</b> . . . . .	<b>29</b>
<b>3</b>	<b>Ordering information</b> . . . . .	<b>2</b>	<b>10</b>	<b>Dynamic characteristics</b> . . . . .	<b>30</b>
<b>4</b>	<b>Block diagram</b> . . . . .	<b>3</b>	10.1	Timing diagrams . . . . .	31
<b>5</b>	<b>Pinning information</b> . . . . .	<b>4</b>	<b>11</b>	<b>Package outline</b> . . . . .	<b>39</b>
5.1	Pinning . . . . .	4	<b>12</b>	<b>Soldering</b> . . . . .	<b>41</b>
5.2	Pin description . . . . .	5	12.1	Introduction to soldering surface mount packages . . . . .	41
<b>6</b>	<b>Functional description</b> . . . . .	<b>9</b>	12.2	Reflow soldering . . . . .	41
6.1	Internal registers . . . . .	9	12.3	Wave soldering . . . . .	41
6.2	FIFO operation . . . . .	10	12.4	Manual soldering . . . . .	42
6.3	Hardware flow control . . . . .	11	12.5	Package related soldering information . . . . .	42
6.4	Time-out interrupts . . . . .	11	<b>13</b>	<b>Revision history</b> . . . . .	<b>43</b>
6.5	Programmable baud rate generator . . . . .	12	<b>14</b>	<b>Data sheet status</b> . . . . .	<b>44</b>
6.6	DMA operation . . . . .	13	<b>15</b>	<b>Definitions</b> . . . . .	<b>44</b>
6.7	Sleep mode . . . . .	14	<b>16</b>	<b>Disclaimers</b> . . . . .	<b>44</b>
6.8	Loop-back mode . . . . .	14			
<b>7</b>	<b>Register descriptions</b> . . . . .	<b>16</b>			
7.1	Transmit (THR) and Receive (RHR) Holding Registers . . . . .	17			
7.2	Interrupt Enable Register (IER) . . . . .	17			
7.2.1	IER versus Receive FIFO interrupt mode operation . . . . .	18			
7.2.2	IER versus Receive/Transmit FIFO polled mode operation . . . . .	18			
7.3	FIFO Control Register (FCR) . . . . .	19			
7.3.1	DMA mode . . . . .	19			
7.3.2	FIFO mode . . . . .	19			
7.4	Interrupt Status Register (ISR) . . . . .	21			
7.5	Line Control Register (LCR) . . . . .	22			
7.6	Modem Control Register (MCR) . . . . .	24			
7.7	Line Status Register (LSR) . . . . .	25			
7.8	Modem Status Register (MSR) . . . . .	26			
7.9	Scratchpad Register (SPR) . . . . .	27			
7.10	Enhanced Feature Register (EFR) . . . . .	27			
7.11	SC16C750 external reset conditions . . . . .	28			



**PHILIPS**

*Let's make things better.*